

# TOWN OF WHITESTOWN BOONE COUNTY, INDIANA

## STANDARD DETAILS



ADOPTED \_\_\_\_\_ AUGUST 14, 2012

UPDATED \_\_\_\_\_ MAY, 2015

### TOWN OF WHITESTOWN - STAFF

TOWN MANAGER - DAX NORTON  
 PUBLIC WORKS DIRECTOR - JASON LAWSON  
 TOWN CLERK - AMANDA ANDREWS  
 POLICE CHIEF - DENNIS ANDERSON  
 FIRE CHIEF - JOSH WESTRICH

### TOWN OF WHITESTOWN - COUNCIL

PRESIDENT - ERIC MILLER  
 MEMBER - SUSAN AUSTIN  
 MEMBER - KEVIN RUSSELL  
 MEMBER - DAWN SEMMLER  
 MEMBER - JULIE WHITMAN

TOWN HALL - (317) 769-6557  
 UTILITY OFFICE - (317) 733-8584

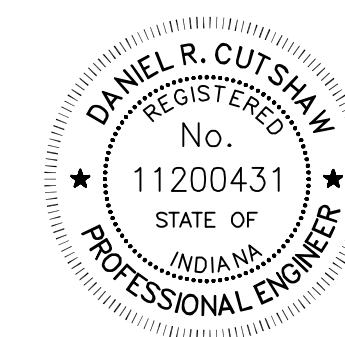

*D.R. Cutshaw*

DRAWING INDEX	
SHT. NO.	DRAWING TITLE
--	COVER
1	STANDARD DETAILS FOR WATER MAINS
2	STANDARD DETAILS FOR WATER MAINS
3	STANDARD DETAILS FOR WATER MAINS
4	STANDARD DETAILS FOR SANITARY SEWERS
5	STANDARD DETAILS FOR SANITARY SEWERS
6	STANDARD DETAILS FOR SANITARY SEWERS
7	STANDARD DETAILS FOR STREETS
8	STANDARD DETAILS FOR STREETS
9	STANDARD DETAILS FOR ROADS
10	LIFT STATION SITE LAYOUT AND ELECTRICAL DIAGRAM
11	LIFT STATION GENERAL CONFIGURATION



TOWN OF WHITESTOWN  
STANDARD DETAILS FOR WATER MAINS

NO.	DATE	DESCRIPTION

SCALE: N.T.S.  
SHEET NO.

**WATER MAIN GENERAL NOTES**

1. WATER MAINS TO BE EITHER DUCTILE IRON, CLASS 350 PER AWWA C151, DOUBLE CEMENT MORTAR LINED, OR PVC C900, DR14. JOINTS SHALL BE PUSH ON ELASTOMERIC TYPE. SEE SPECIFICATIONS FOR MORE DETAILS.
2. ALL FITTINGS TO BE DUCTILE IRON, CLASS 350 (AWWA C153) MECHANICAL JOINT (AWWA C111) WITH RESTRAINED OR LOCK JOINT. THRUST BLOCKS NOT ACCEPTABLE.
3. TERMINATE LOCATION WIRE AT WATER MAIN GATE VALVE WITH TERMINAL CONNECTION.
4. LOCATION WIRE SHALL BE COLORED BLUE FOR WATER AND GREEN FOR SANITARY SEWER. JOINTS IN LOCATE WIRES SHALL BE OVERHAND KNOTTED AND SOLDERED THEN COVERED WITH A WATER PROOF SEAL.
5. ALL NEW OR REPAIRED WATER MAIN SHALL BE DISINFECTED IN ACCORDANCE WITH AWWA 651 AND HYDROSTATIC TESTED IN ACCORDANCE WITH AWWA C600 PRIOR TO BEING PLACED IN SERVICE.
6. VALVES AND FIRE HYDRANTS SHALL BE PROVIDED AT MAXIMUM 600' INTERVALS ALONG WATER MAINS.
7. ALL WATER MAINS PROVIDING FIRE SERVICE SHALL BE MIN. 6" DIAMETER.
8. IN UNDEVELOPED AREAS, WATER MAIN MARKER POSTS MAY BE REQUIRED AT 400' INTERVALS OR AS REQUIRED FOR LINE OF SIGHT. HANDLE INDUSTRIES OR EQUAL.

WATER METER SETTING SCHEDULE						
STYLE	SINGLE 5/8"	DOUBLE 5/8"	SINGLE 3/4"	DOUBLE 3/4"	SINGLE 1"	SINGLE 1 1/2"-2"
INLET	3/4" COMP.	1" COMP.	3/4" COMP.	1" COMP.	1" COMP.	1 1/2"-2" COMP.
OUTLET	3/4" COMP.	3/4" COMP.	3/4" COMP.	3/4" COMP.	1" COMP.	1 1/2"-2" COMP.

**WATER METER AND SERVICE NOTES:**

1. ALL 1"-2" TAPS TO PVC PIPE WILL USE A SMITH BLAIR #317 STYLE EPOXY COATED DUCTILE IRON SERVICE SADDLE WITH DOUBLE STAINLESS STEEL BANDS OR APPROVED EQUAL. DUCTILE IRON PIPE MAY BE DIRECT TAPPED. TAPS SHALL BE ANGLED UP 45° AT CONNECTION TO MAIN.
  2. MINIMUM 6" OF WASHED AGGREGATE WILL BE USED UNDER ALL METER PITS FOR DRAINAGE.
  3. ALL METERS LARGER THAN 2" WILL BE SUPPLIED BY THE CONTRACTOR, FROM TOWN'S VENDOR.
  4. ALL TUBING CONNECTIONS WILL BE DONE WITH MUELLER OR McDONALD BRASS COMPRESSION FITTINGS.
  5. ALL CORPORATION AND CURB STOPS WILL BE MUELLER 300 BALL VALVE OR McDONALD EQUIVALENT.
  6. ALL RESIDENTIAL CONSTRUCTION REQUIRES THE USE OF DUAL METER INSTALLATIONS WHENEVER POSSIBLE. ANY EXCEPTIONS WILL NEED THE APPROVAL OF THE UTILITY MANAGER.
  7. FINAL GRADE OF METER PIT IS THE SOLE RESPONSIBILITY OF THE DEVELOPER. NO MORE THAN MAX. 12" RISER MAY BE ADDED IN ORDER TO BRING PIT TO GRADE.
  8. METER PIT LIDS SHALL BE CAST IRON WITH LARGE PENTAGON NUT (MUELLER OR TYLER). METER PIT LIDS SHALL HAVE HOLES FOR RADIO READ ANTENNA MOUNTING (TWO HOLES ON DUAL METER PIT).
  9. ALTERNATE FOR MUELLER WILL BE A.Y. McDONALD BRASS. A LIST OF THOSE SPECIFICATION NUMBERS IS AVAILABLE UPON REQUEST FROM THE TOWN OF WHITESTOWN UTILITY MANAGER.
  10. THE DEVELOPER SHALL SUBMIT FIXTURE UNIT FLOW AND PRESSURE LOSS CALCULATIONS FOR THE TOWN'S REVIEW AND APPROVAL FOR ANY PLANNED MULTI-FAMILY, COMMERCIAL, OR INDUSTRIAL CONNECTION.
- WATER METERS FOR COMMERCIAL MECHANICAL ROOMS  
INDOOR COMMERCIAL WATER METERS UP TO 2" SHALL HAVE COPPER METER YOKES WITH HORIZONTAL INLET & OUTLET AND LOCKABLE BY-PASS, EQUIVALENT TO MUELLER B-2423-2. LARGER METERS SHALL BE EVALUATED ON A CASE-BY-CASE BASIS, BUT SHALL GENERALLY BE MOUNTED HORIZONTALLY WITH PIPING CONFIGURED SIMILAR TO THE VAULT DETAIL ON SHEET 2. A REMOTE DIGITAL METER READOUT SHALL BE INSTALLED ON THE OUTSIDE OF THE BUILDING TO FACILITATE METER READING. COORDINATE INSTALLATION WITH THE TOWN OF WHITESTOWN. MEANS OF ACCESS FOR THE TOWN SHALL BE PROVIDED TO INDOOR METERS AT ALL TIMES.

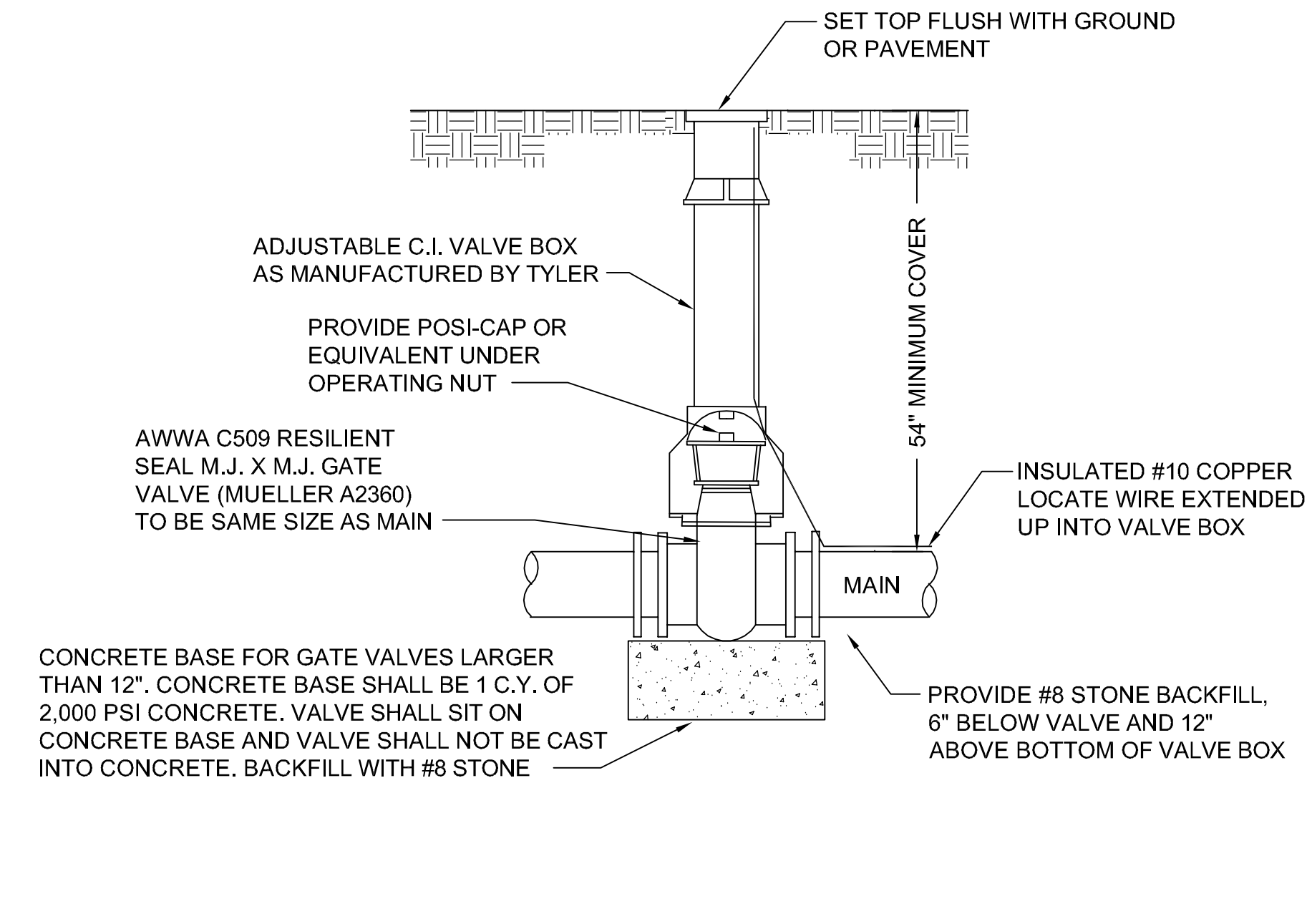

**TYPICAL GATE VALVE & VALVE BOX**

NOT TO SCALE

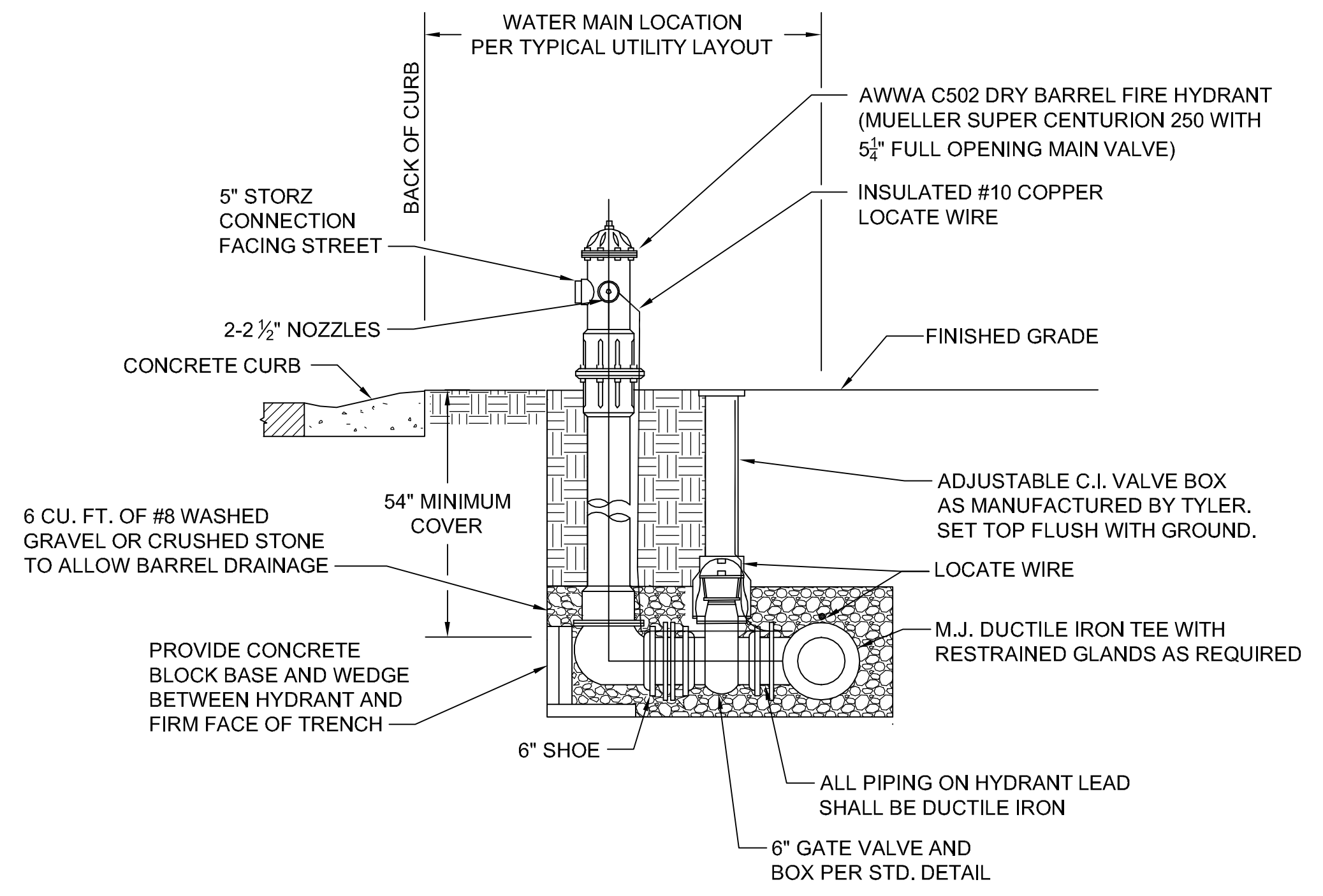

**STANDARD FIRE HYDRANT**

NOT TO SCALE

NOTE:  
SNOWPLOWABLE BLUE REFLECTORS SHALL BE INSTALLED IN CENTER OF ROAD AT ALL FIRE HYDRANTS; PROVIDE TOWN WITH AN OPERATING WRENCH AND TRAFFIC DAMAGE REPAIR KIT(S). SEE TOWN SPECIFICATIONS.

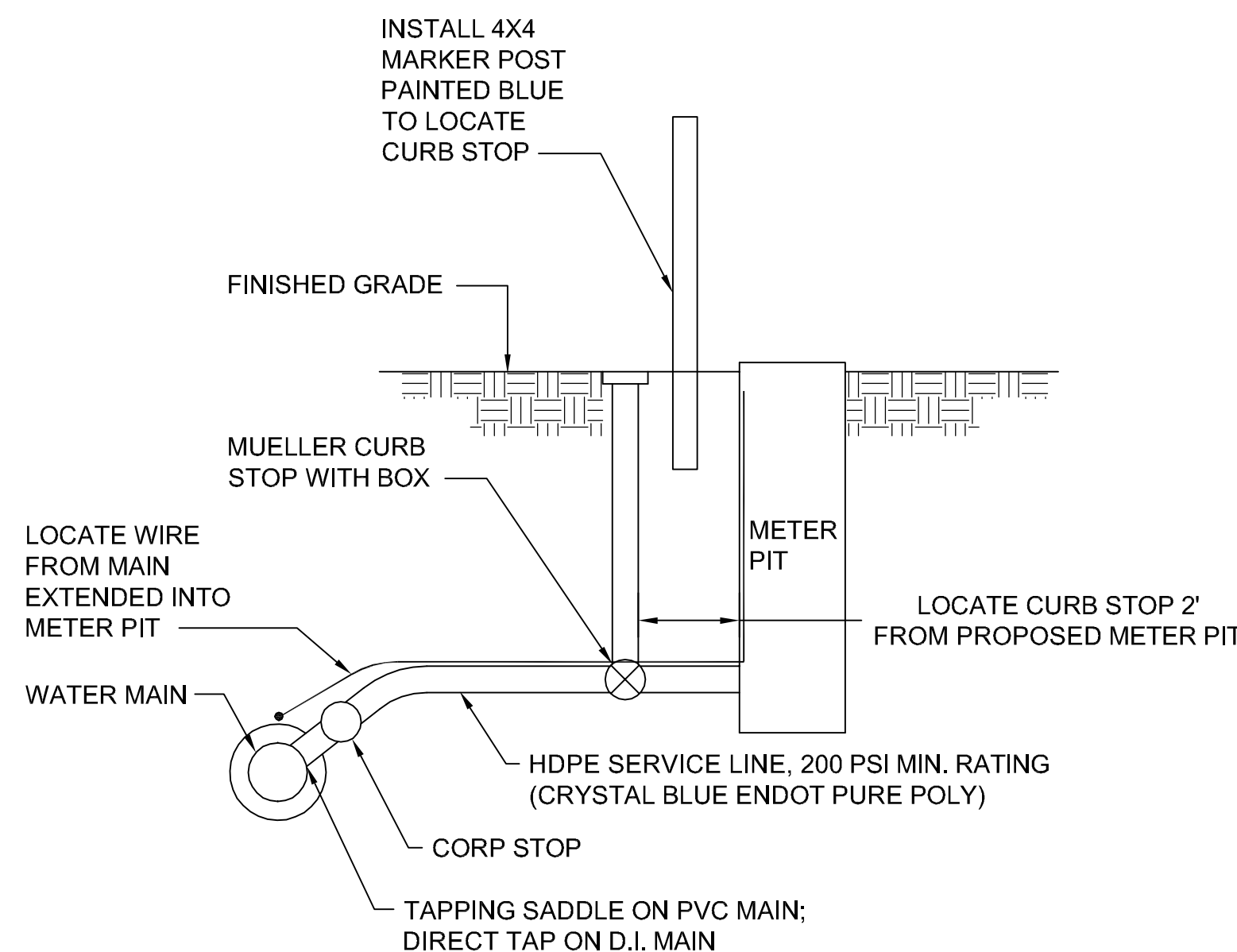

**WATER SERVICE CONNECTION DETAIL**

NOT TO SCALE

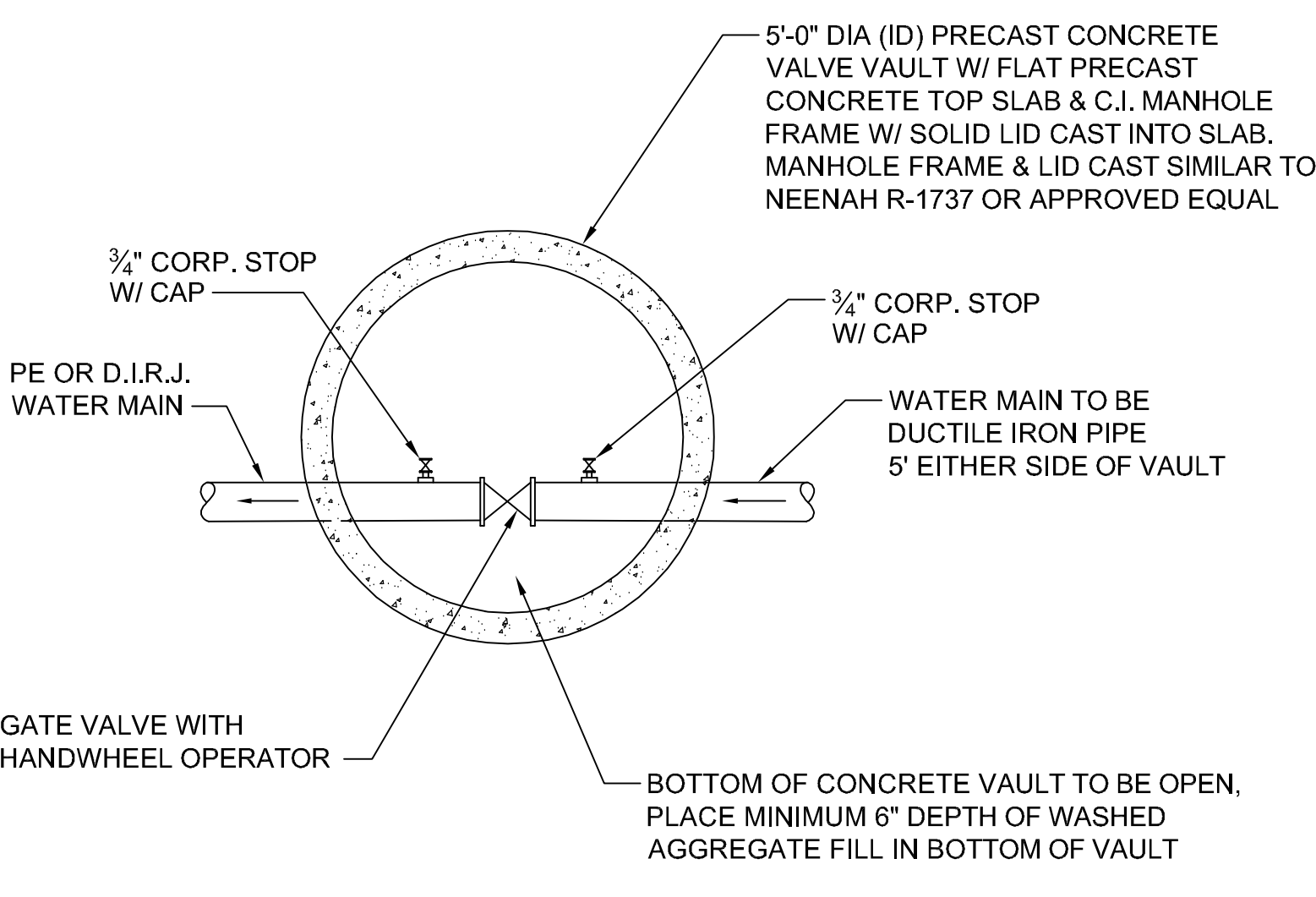

**LEAK DETECTION METER DETAIL**

NOT TO SCALE

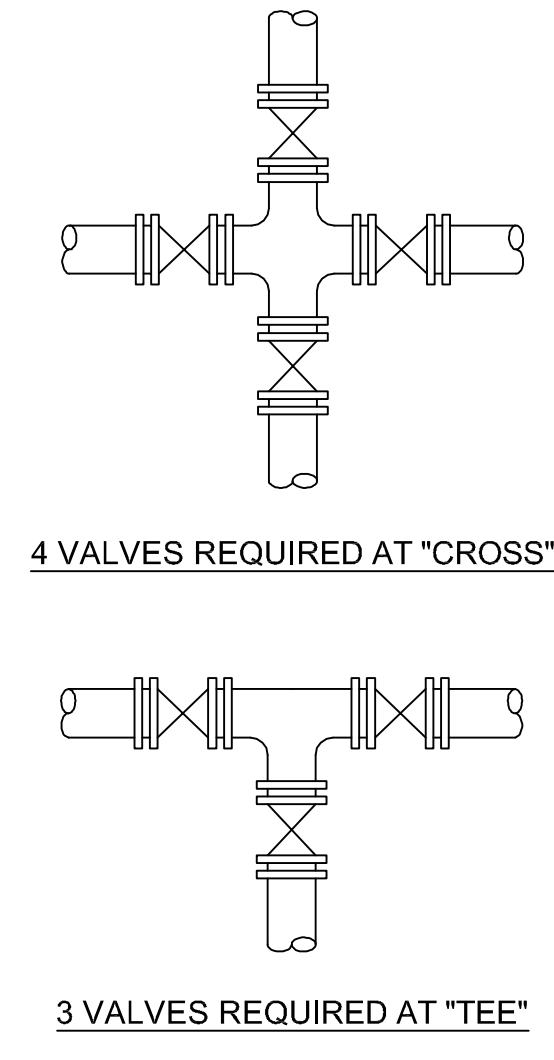

**VALVE DETAILS AT INTERSECTIONS**

NOT TO SCALE

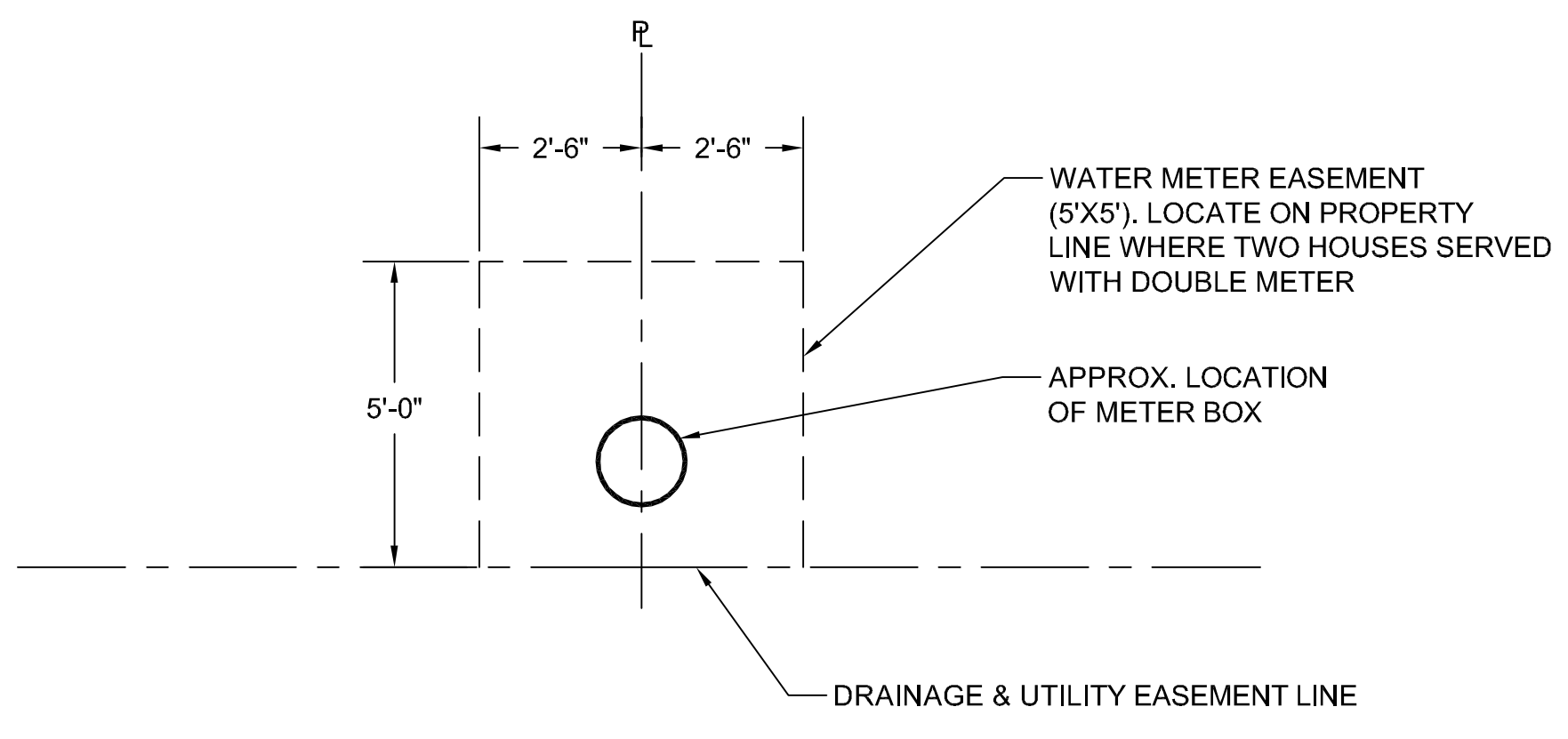

**METER PIT EASEMENT DIAGRAM**

NOT TO SCALE

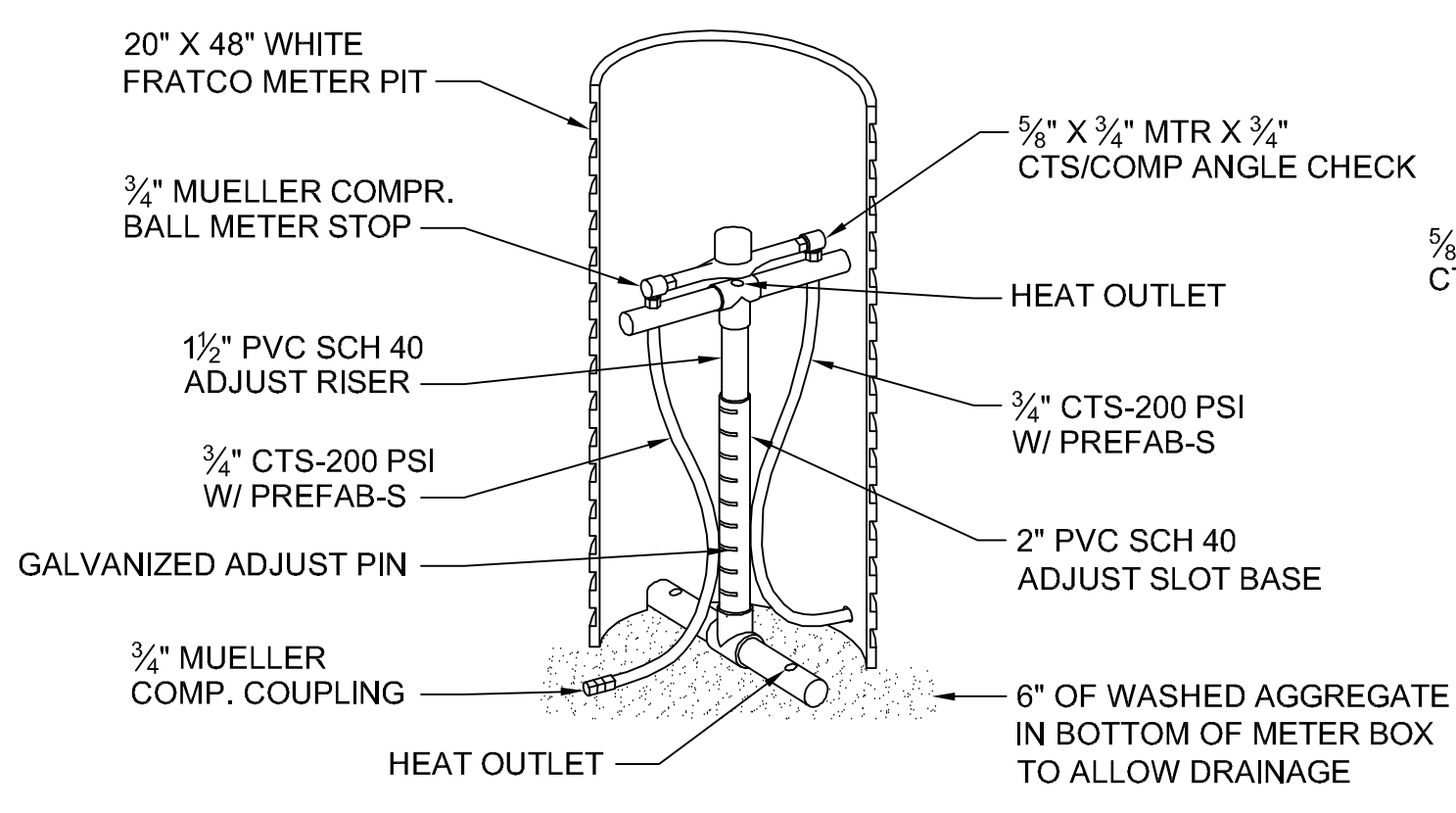

**TZ PRODUCTS SINGLE METER BOX**

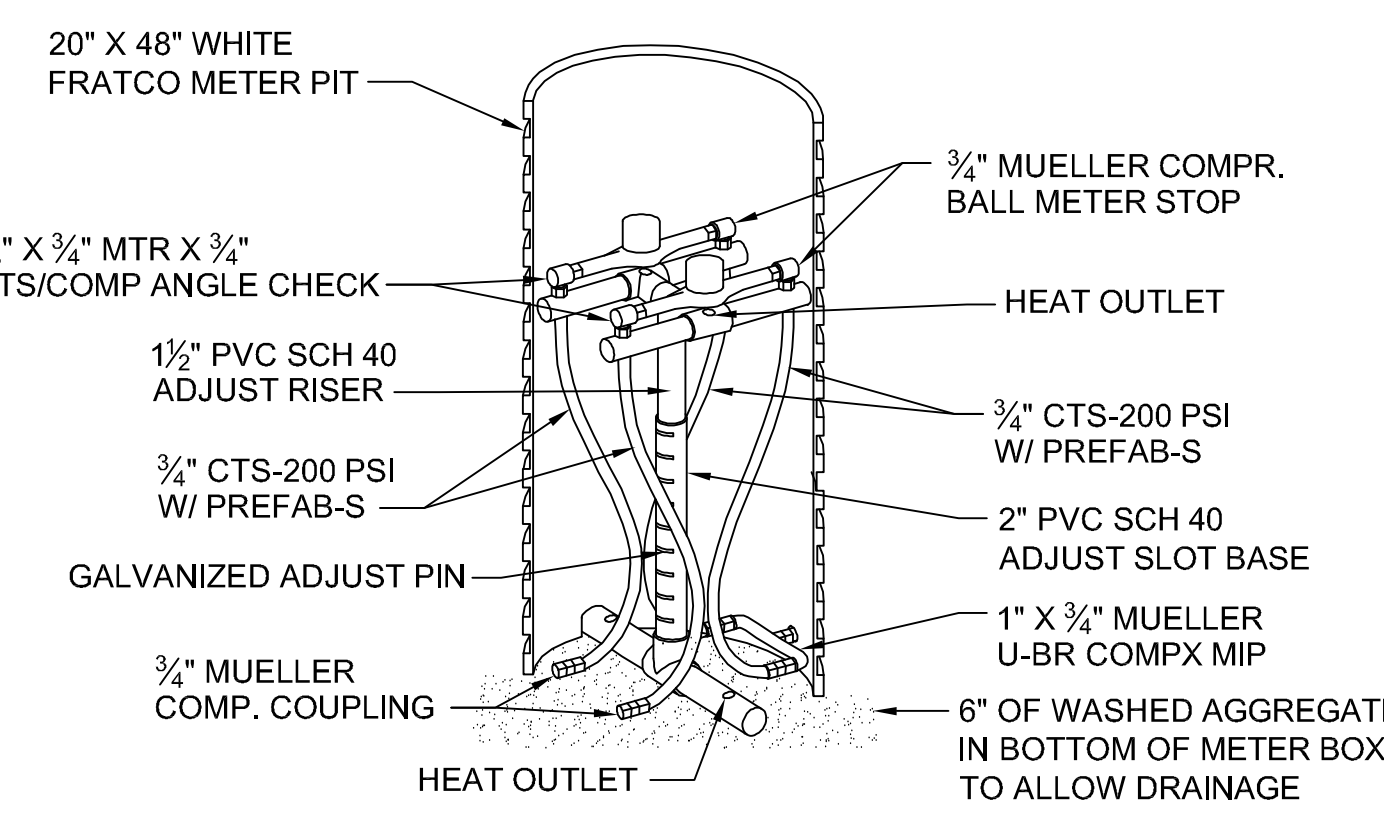

**TZ PRODUCTS DOUBLE METER BOX**

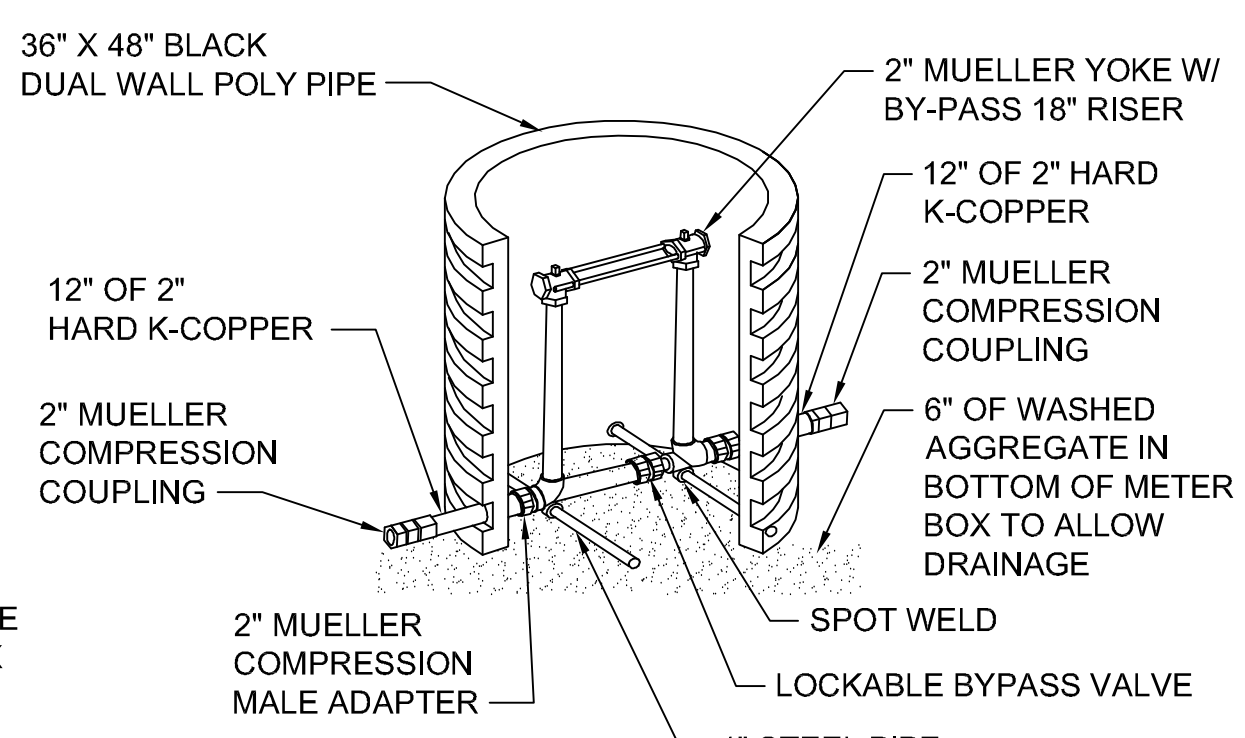

**TZ PRODUCTS 2" SINGLE METER BOX**

**METER BOX AND METER SETTING**

NOT TO SCALE

PRINTED: 7/30/2015 @ 2:45PM  
FILE NAME: L:\AutoCAD Resources\Inky\_Sanitary\Client\Standards\Whitestown - 120409\Details 2015\SHEET\_01\_WATER.dwg



TOWN OF WHITESTOWN  
STANDARD DETAILS FOR WATER MAINS

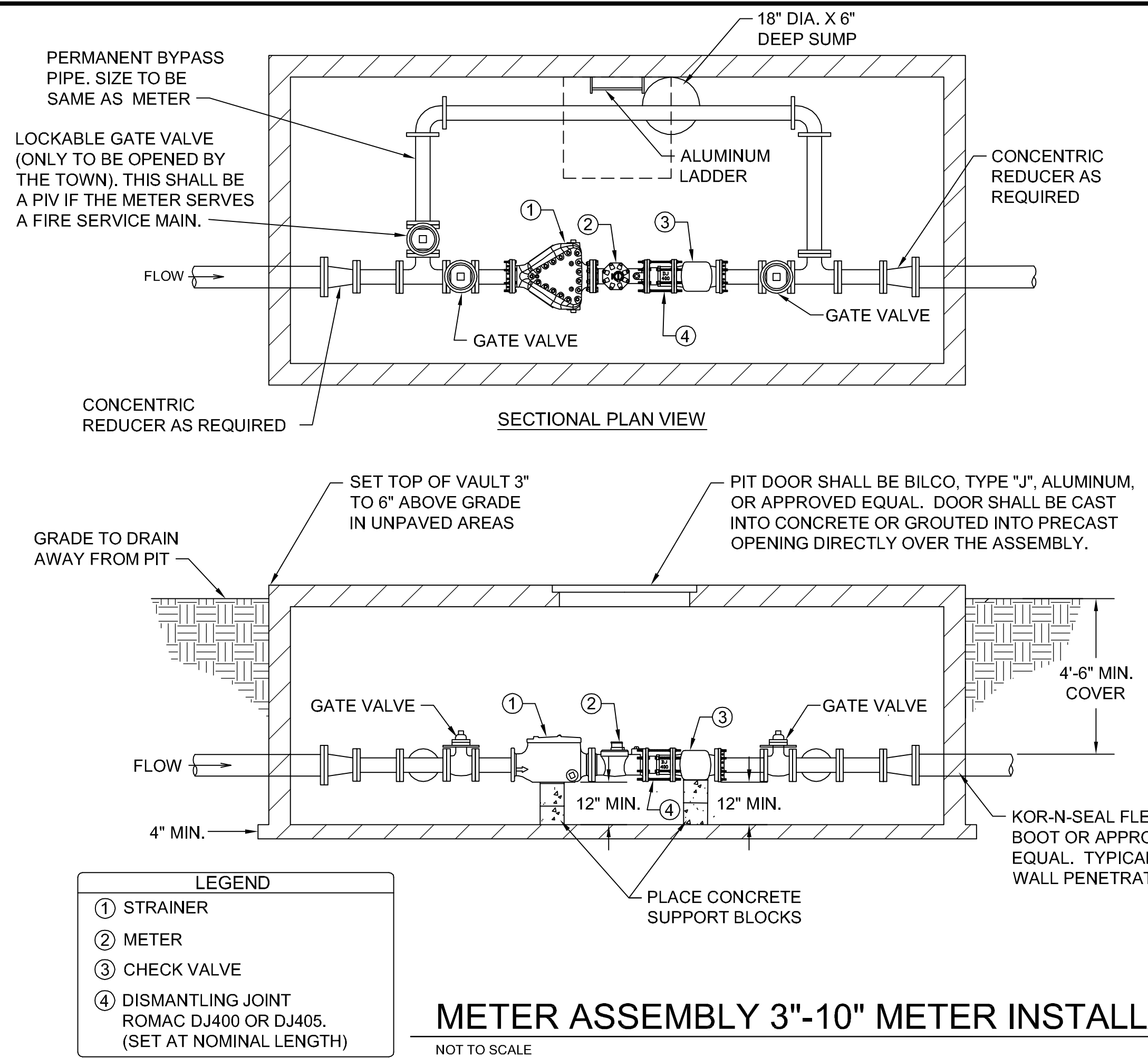

- LEGEND**
- ① STRAINER
  - ② METER
  - ③ CHECK VALVE
  - ④ DISMANTLING JOINT ROMAC DJ400 OR DJ405. (SET AT NOMINAL LENGTH)

**METER ASSEMBLY 3"-10" METER INSTALLATION**  
NOT TO SCALE

- NOTES:**
1. VAULT IS A GENERAL REPRESENTATION ONLY. THE DEVELOPER'S ENGINEER SHALL SUBMIT A SPECIFIC VAULT DETAIL FOR THE PLANNED FACILITY.
  2. ALL METER ASSEMBLIES SHALL BE SPECIFIED BY THE TOWN OF WHITESTOWN. THE DEVELOPER'S ENGINEER SHALL PROVIDE FIXTURE UNIT FLOW AND PRESSURE LOSS CALCULATIONS FOR THE TOWN'S REVIEW AND ACCEPTANCE TO ALLOW A PROPER METER TO BE SELECTED.
  3. EACH METER VAULT SHALL BE EQUIPPED WITH A DOOR MOUNTED ELECTRONIC DEVICE FOR USE WITH A RADIO READING SYSTEM.
  4. ALL FITTINGS SUCH AS BENDS AND TEES SHALL BE PROPERLY RESTRAINED.
  5. VAULT SIZE TO PROVIDE 12" MINIMUM CLEARANCE FROM ALL PIPING AND FITTINGS.
  6. PIT/VAULT (NON-TRAFFIC AREA) PIT SHALL BE REINFORCED CAST-IN-PLACE CONCRETE, PRECAST CONCRETE, OR LAID BLOCK. APPLY APPROVED WATERPROOFING AGENT TO INTERIOR AND EXTERIOR OF WALLS. SPECIFICATIONS FOR PITS IN TRAFFIC AREAS SHALL BE DETERMINED BY DESIGN REQUIREMENTS.
  7. INTERIOR PIPING SHALL BE D.I.F.L.

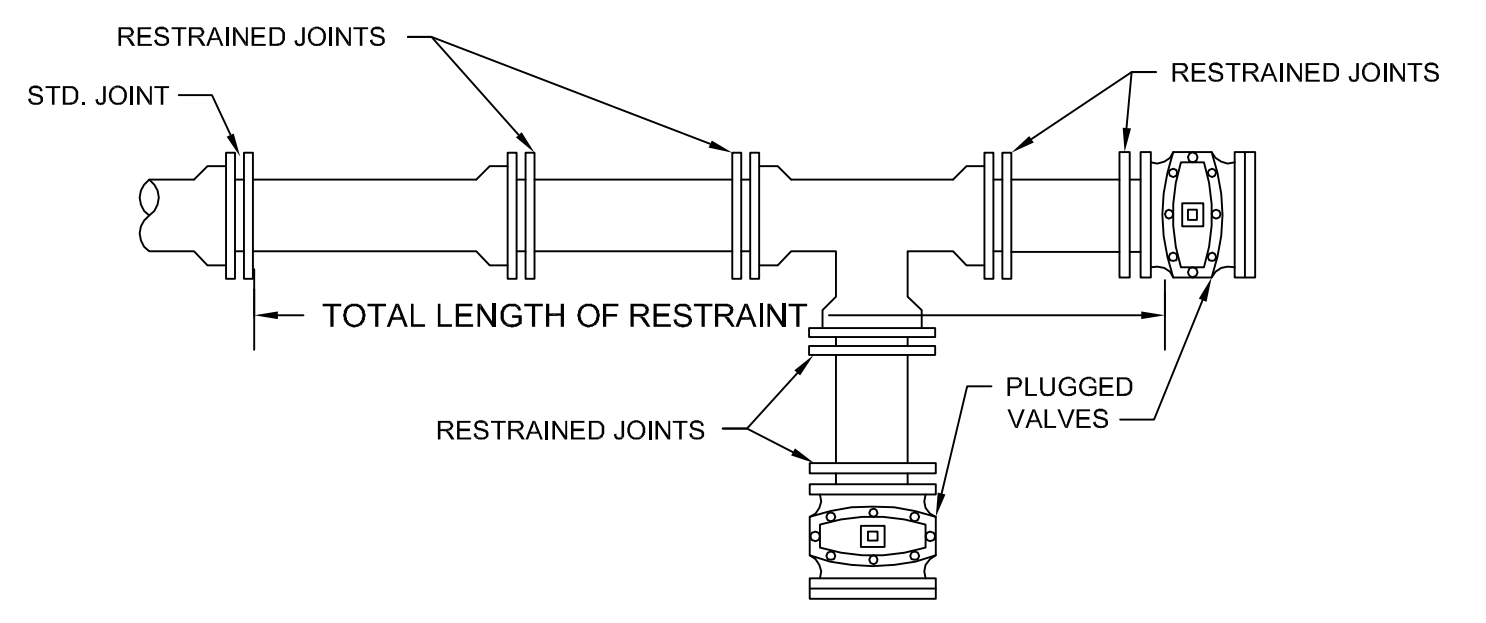

**DEAD ENDS OF TEES**

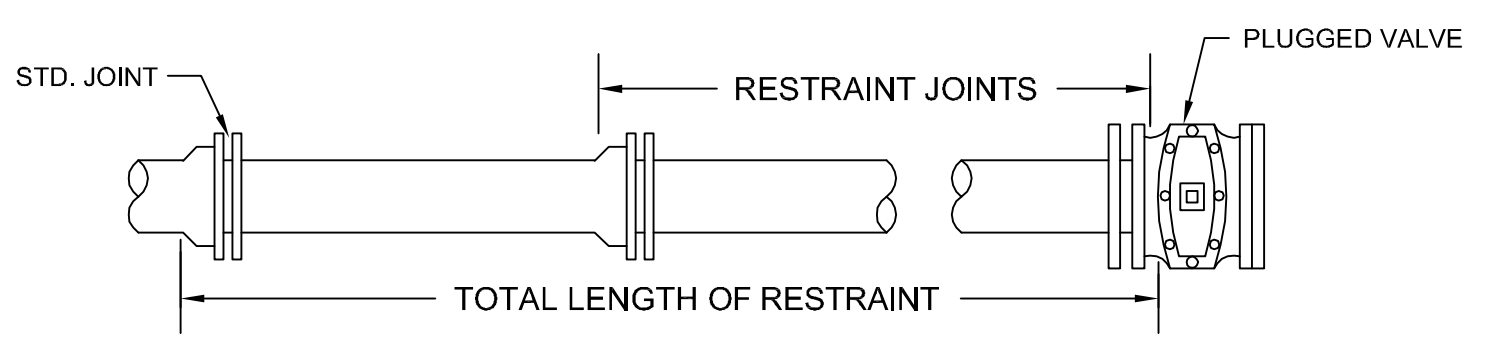

**DEAD ENDS OF MAINS**

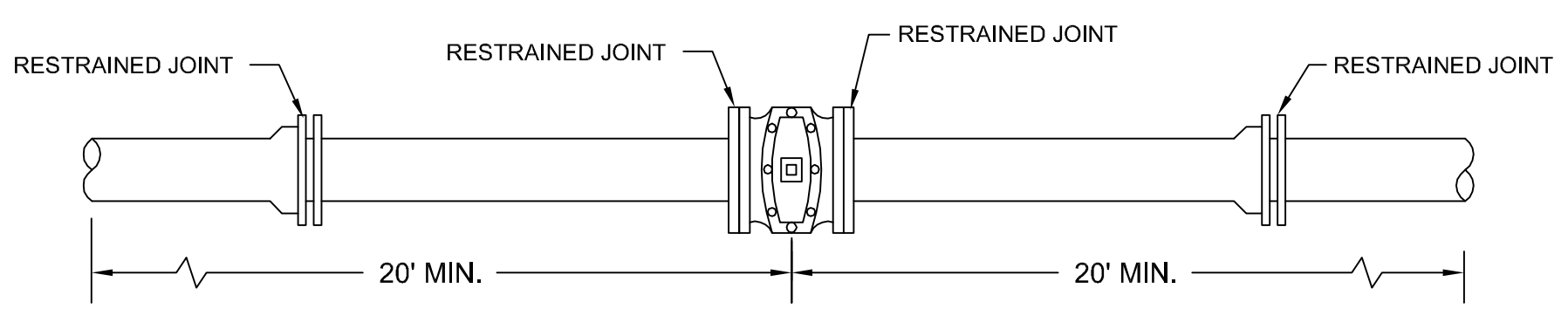

**VALVES (NON-DEAD END) 8" AND SMALLER**

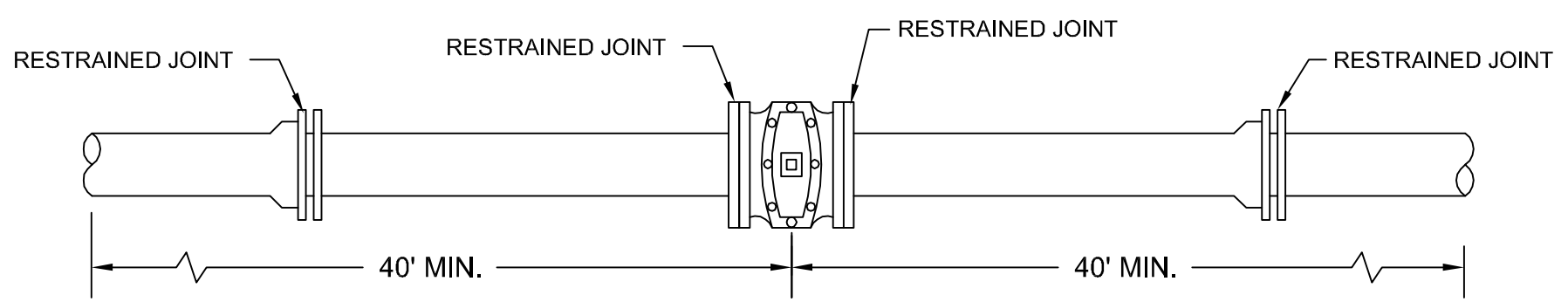

**VALVES (NON-DEAD END) 12" AND LARGER**

**RESTRAINING VALVES-DETAIL**

NOT TO SCALE

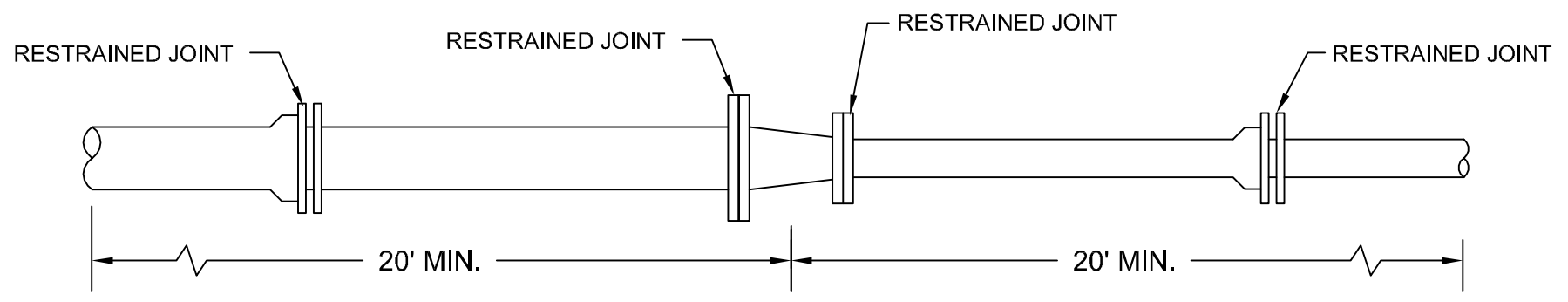

**REDUCERS, LARGER PIPE DIAMETER IS 8" OR SMALLER**

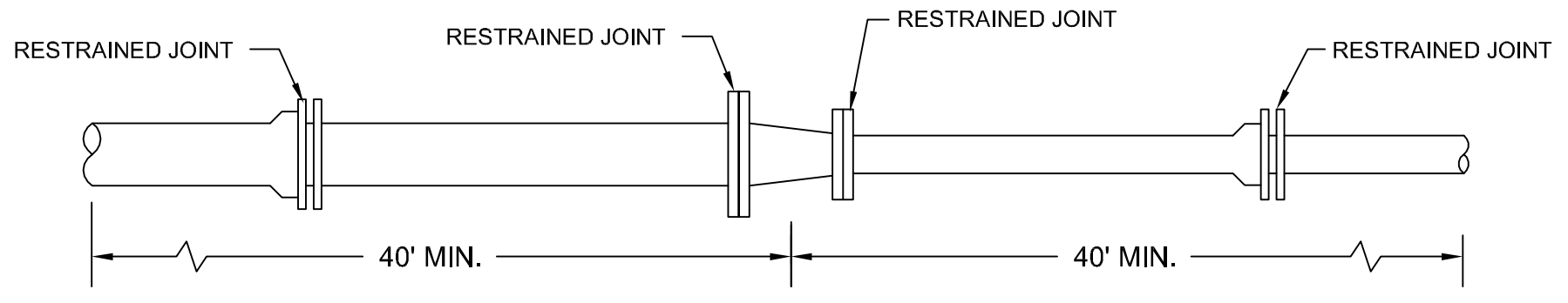

**REDUCERS, LARGER PIPE DIAMETER IS 12" OR LARGER**

**RESTRAINING REDUCERS-DETAIL**

NOT TO SCALE

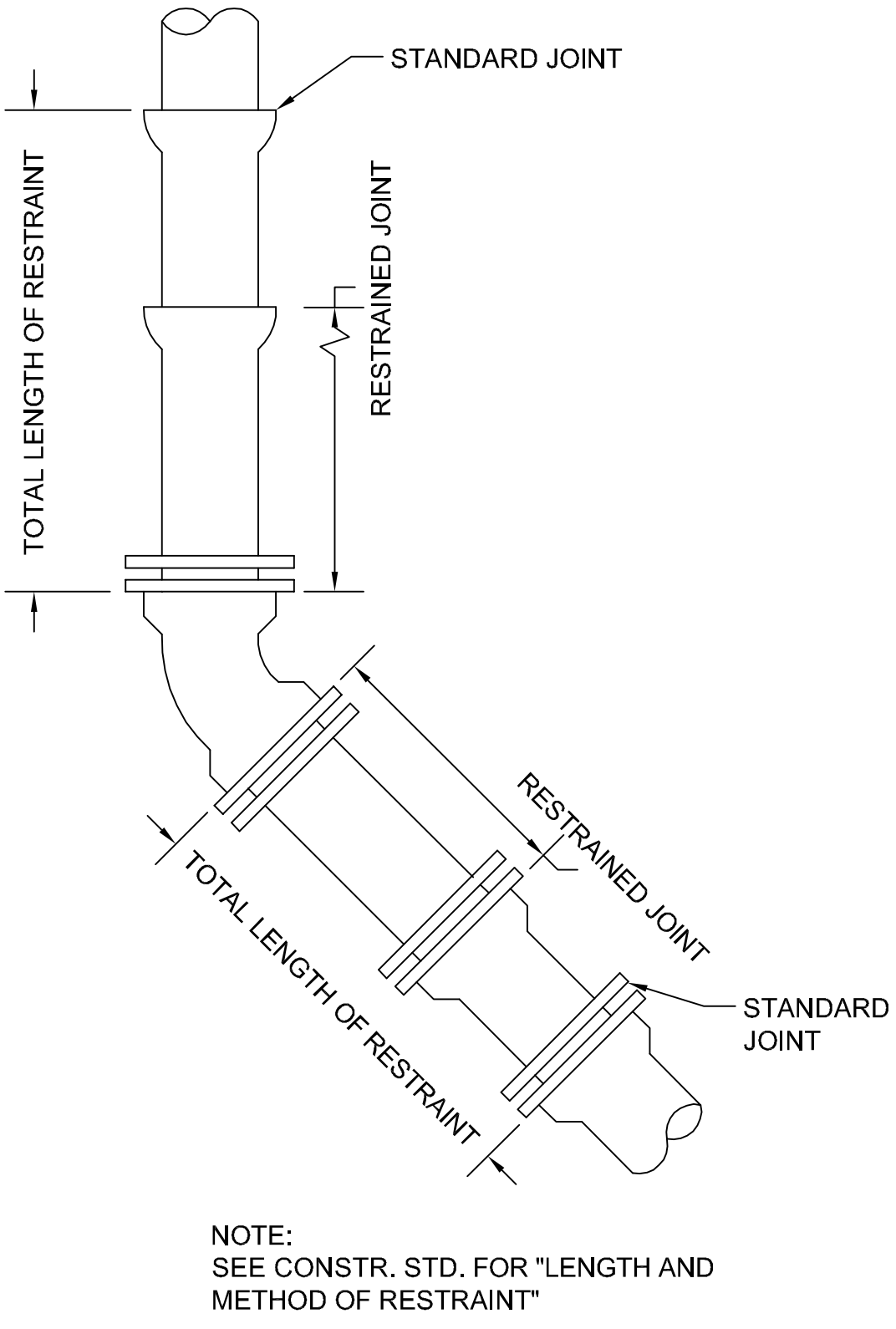

**RESTRAINT OF BENDS-DETAIL**

NOT TO SCALE

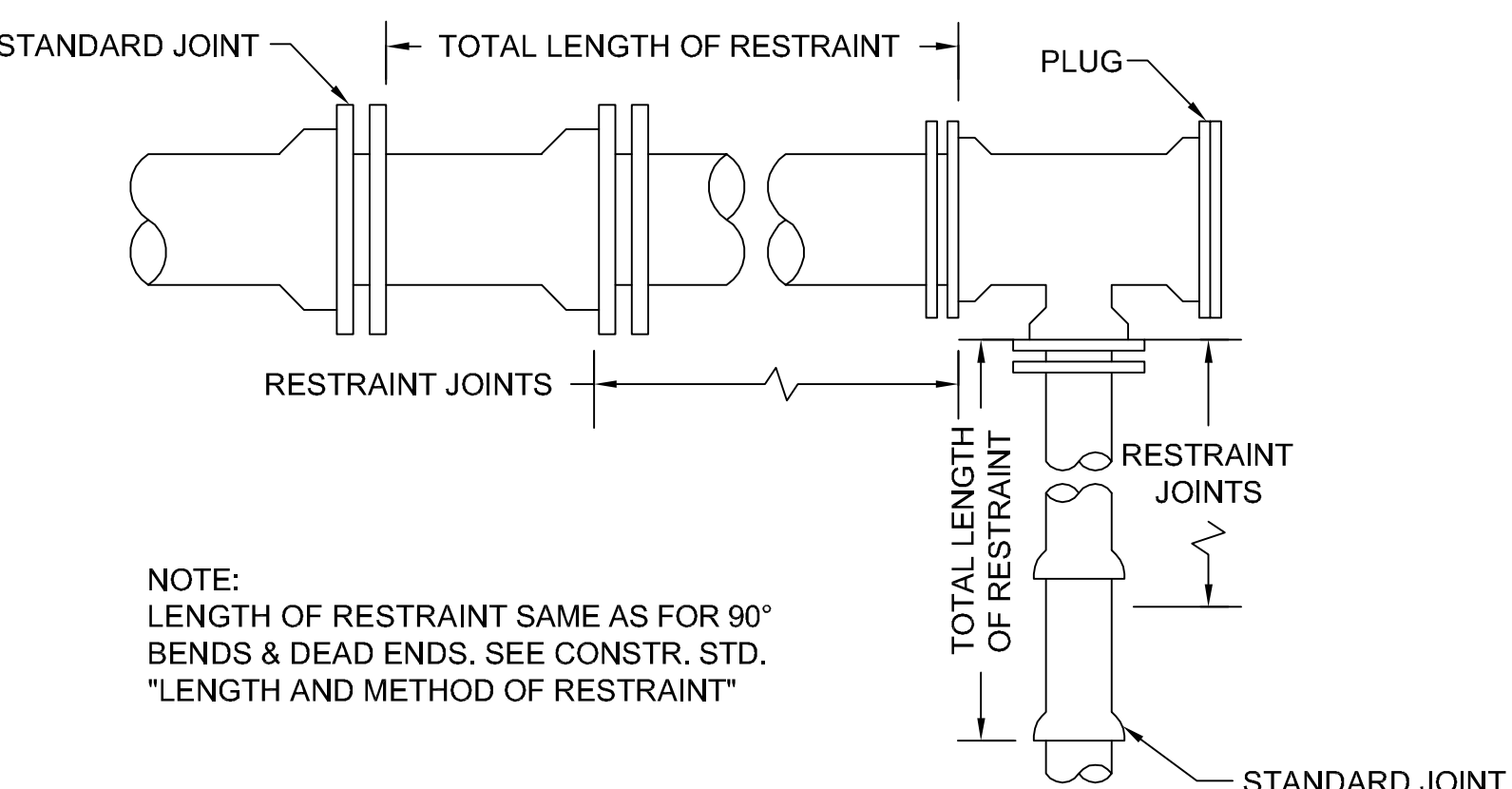

**RESTRAINT OF TEES-DETAIL**

NOT TO SCALE

LENGTH IN FT. TO BE REST. ON EACH SIDE OF FITTING FOR 4" DI PIPE W/ POLY

TYPE OF BEND	4" TEE	90° BEND	45° BEND	22 1/2° BEND	11 1/4° BEND	DEADENDS
HORIZ. BEND	44	18	10	10	10	53
VERT. BEND				22 UPPER	11 UPPER	10 UPPER
				10 LOWER	10 LOWER	10 LOWER

LENGTH IN FT. TO BE REST. ON EACH SIDE OF FITTING FOR 12" DI PIPE W/ POLY

TYPE OF BEND	4" TEE	6" TEE	8" TEE	10" TEE	12" TEE	90° BEND	45° BEND	22 1/2° BEND	11 1/4° BEND	DEADENDS	
HORIZ. BEND	28	58	89	116	144	49	21	10	10	152	
VERT. BEND							63 UPPER	31 UPPER	15 UPPER		
							17 LOWER	10 LOWER	10 LOWER		

LENGTH IN FT. TO BE REST. ON EACH SIDE OF FITTING FOR 6" DI PIPE W/ POLY

TYPE OF BEND	4" TEE	6" TEE	90° BEND	45° BEND	22 1/2° BEND	11 1/4° BEND	DEADENDS
HORIZ. BEND	39	66	25	11	10	10	74
VERT. BEND				31 UPPER	15 UPPER	10 UPPER	
				10 LOWER	10 LOWER	10 LOWER	

LENGTH IN FT. TO BE REST. ON EACH SIDE OF FITTING FOR 16" DI PIPE W/ POLY

TYPE OF BEND	4" TEE	6" TEE	8" TEE	10" TEE	12" TEE	16" TEE	90° BEND	45° BEND	22 1/2° BEND	11 1/4° BEND	DEADENDS
HORIZ. BEND	19	48	79	105	133	188	63	26	13	10	196
VERT. BEND							82 UPPER	39 UPPER	20 UPPER		
							22 LOWER	11 LOWER	10 LOWER		

LENGTH IN FT. TO BE REST. ON EACH SIDE OF FITTING FOR 8" DI PIPE W/ POLY

TYPE OF BEND	4" TEE	6" TEE	8" TEE	90° BEND	45° BEND	22 1/2° BEND	11 1/4° BEND	DEADENDS
HORIZ. BEND	34	62	89	32	14	10	10	97
VERT. BEND				41 UPPER	20 UPPER	11 UPPER		
				12 LOWER	10 LOWER	10 LOWER		

LENGTH IN FT. TO BE REST. ON EACH SIDE OF FITTING FOR 20" DI PIPE W/ POLY

TYPE OF BEND	6" TEE	8" TEE	10" TEE	12" TEE	16" TEE	20" TEE	90° BEND	45° BEND	22 1/2° BEND	11 1/4° BEND	DEADENDS
HORIZ. BEND	27	35	42	50	65	80	55	23	11	10	80
VERT. BEND							45 UPPER	22 UPPER	11 UPPER		
							20 LOWER	10 LOWER	10 LOWER		

**RESTRAINT JOINT TABLES**

NOT TO SCALE

1. CONTRACTOR SHALL INSTALL RJDI FITTINGS FOR ALL VERTICAL AND HORIZONTAL BENDS.
2. RESTRAINED LENGTHS WERE CALCULATED ASSUMING 54" DEPTH OF BURY, A 2.0 FACTOR OF SAFETY, TYPE 3 TRENCH CONDITIONS, "CL" SOIL CLASSIFICATION, AND 150 PSI HYDROSTATIC TEST PRESSURES. DESIGNER AND CONTRACTOR SHALL VERIFY INSTALLATION CONDITIONS AND MODIFY RESTRAINT LENGTHS AS REQUIRED TO MEET ACTUAL CONDITIONS SUBJECT TO REVIEW BY THE TOWN OF WHITESTOWN.
3. ALL WATER MAIN APPURTENANCES WITHIN RJDI LIMITS MUST BE RESTRAINED AT EACH JOINT.

PRINTED: 7/30/2015 @ 2:48PM  
FILE NAME: L:\AutoCAD Resources\Info Sanitary\Client Standards\Whitestown - 120409\Details 2015\SHEET\_02\_WATER.dwg

NO.	DATE	BY	DESCRIPTION

SCALE: N.T.S.

SHEET NO. **2**

NO.	DATE	DESCRIPTION

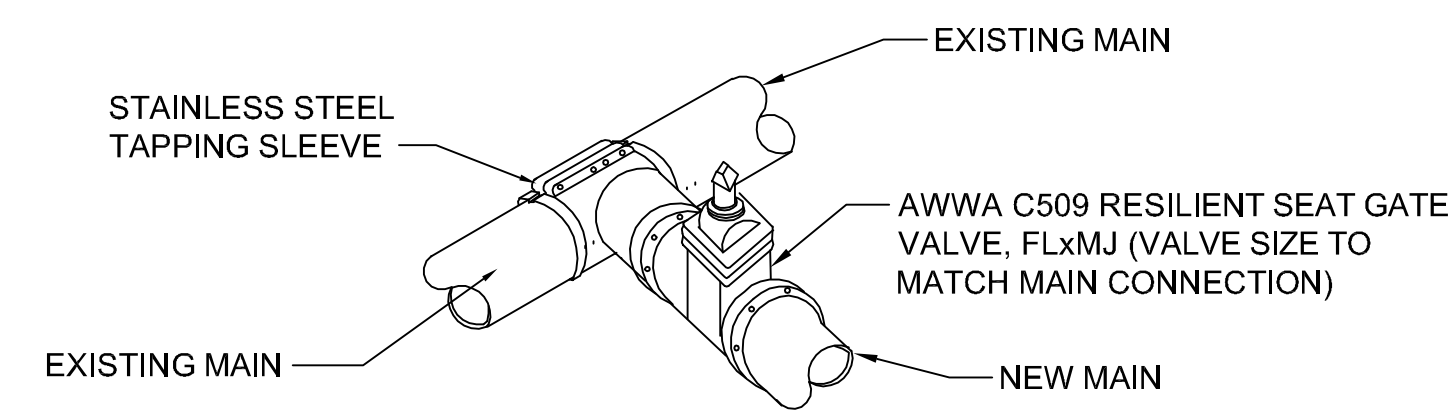

- NOTE:
1. NO MECHANICAL JOINT TAPPING SLEEVES WILL BE ACCEPTED.
  2. BOLTS, NUTS, & WASHERS SHALL BE 304 STAINLESS STEEL.

**WET TAP TO EXISTING MAIN**

NOT TO SCALE

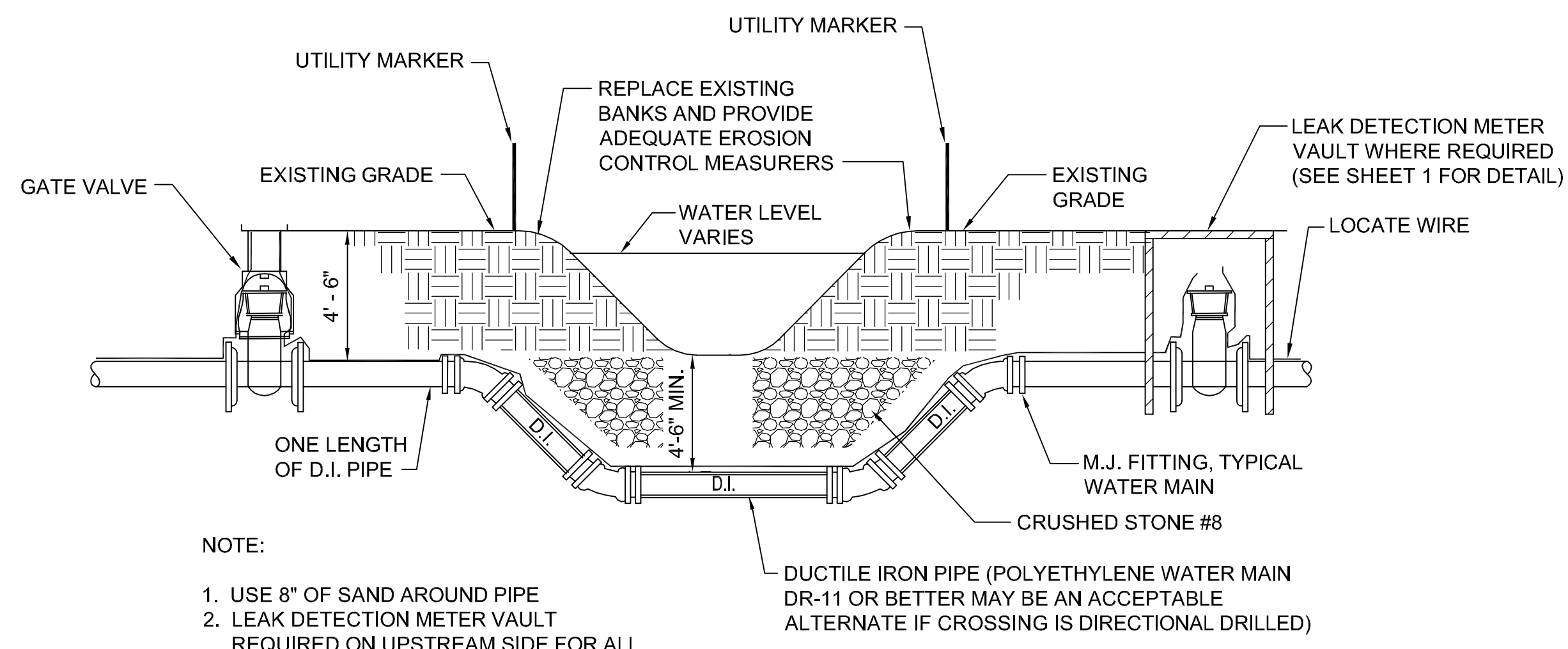

- NOTE:
1. USE 8" OF SAND AROUND PIPE
  2. LEAK DETECTION METER VAULT REQUIRED ON UPSTREAM SIDE FOR ALL CREEK CROSSINGS GREATER THAN 15' IN WIDTH (SEE DETAIL SHEET 2)

**CREEK CROSSING DETAIL**

NOT TO SCALE

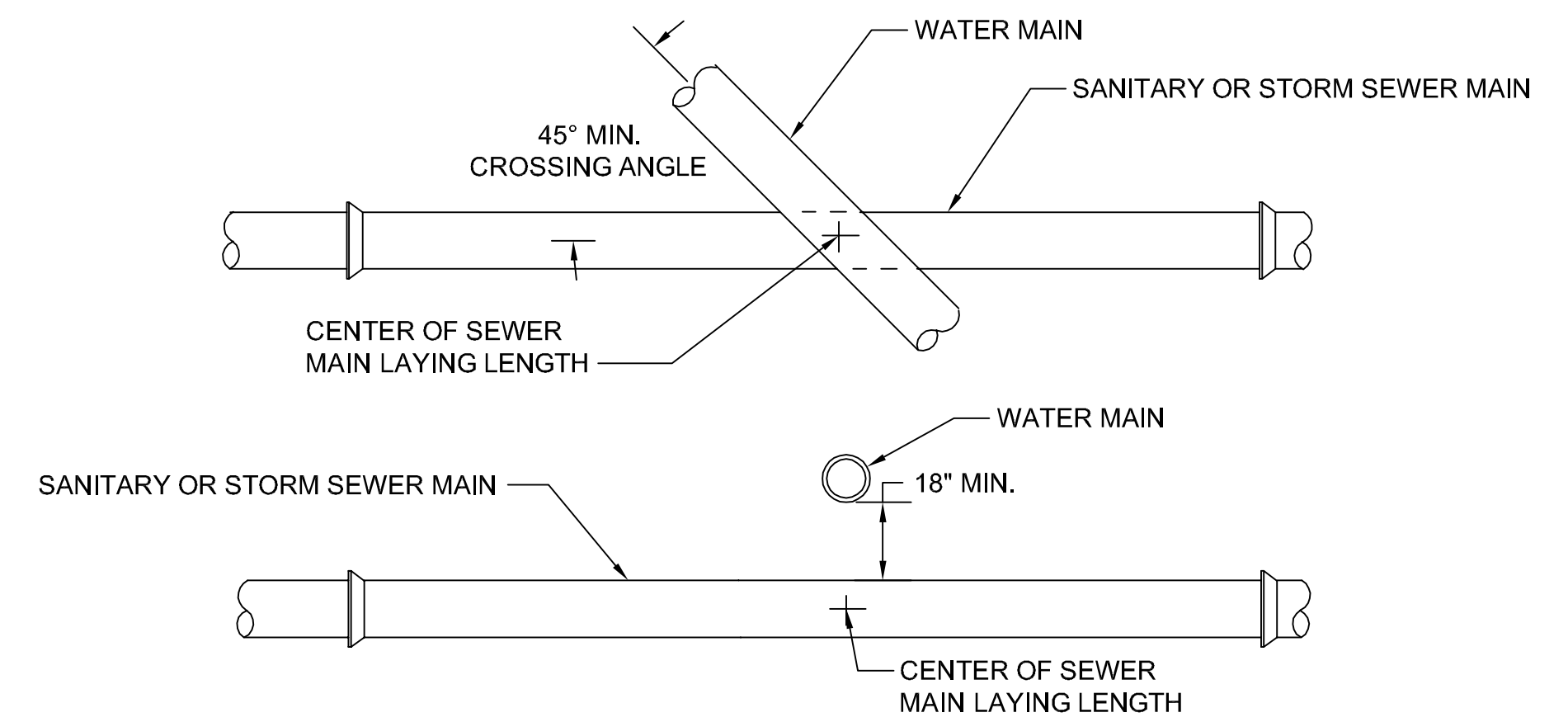

- WATER MAIN AND SEWER MINIMUM SEPARATION:  
18" VERTICAL SEPARATION  
10'-0" HORIZONTAL SEPARATION
- WATER MAIN QUALITY PIPE TO BE USED FOR SANITARY OR STORM SEWER IF REQUIRED SEPARATION CANNOT BE MET.

**MINIMUM CROSSING & SEPARATION REQUIREMENTS FOR WATER AND SANITARY OR STORM SEWER PIPE**

NOT TO SCALE

**NOTES FOR FIRE SERVICES AND OTHER PRIVATE MAINS**

1. PRIVATE FIRE SERVICE MAINS SHALL BE OWNED AND MAINTAINED BY THE PROPERTY OWNER EITHER BEYOND THE SHUT-OFF VALVE LOCATED AT THE R/W/EASEMENT LINE OR BEYOND THE METER.
2. MULTI-UNIT RESIDENTIAL COMPLEXES MAY BE SERVED WITH A COMMON MAIN FOR FIRE AND DOMESTIC SERVICE. MASTER-METERED AT THE ENTRANCE TO THE PROPERTY, WITH FIRE DEPARTMENT CONNECTIONS FOR EACH BUILDING. A FIRE-SERVICE-RATED METER SHALL BE REQUIRED FOR SUCH A CONFIGURATION.
3. ALL PRIVATE MAINS SHALL BE CONSTRUCTED TO MEET OR EXCEED THE SAME STANDARDS AS PUBLIC MAINS IN ADDITION TO ANY APPLICABLE STANDARDS OF THE NFPA, AND SHALL BE HYDROSTATIC TESTED AND DISINFECTED PRIOR TO BEING PLACED INTO SERVICE.
4. THE OWNER SHALL REPAIR ANY LEAKS ON PRIVATE MAINS WITHIN 48 HOURS OF THEIR DISCOVERY. IF THE REPAIR IS NOT COMPLETED WITHIN THIS TIME, THE UTILITY CAN FIX THE LEAK AND CHARGE THE OWNER FOR THE COST OF REPAIRS OR SHUT OFF SERVICE UNTIL THE REPAIR IS MADE.
5. THE DEVELOPER'S ENGINEER SHALL SUBMIT DESIGN CALCULATIONS OF THE PLANNED SYSTEM FOR THE TOWN'S REVIEW.
6. AN APPROVED BACK FLOW PREVENTION DEVICE SHALL BE REQUIRED AT THE CONNECTION TO THE MAIN IF THERE ARE ANY POTENTIAL CROSS CONNECTION SOURCES WITHIN THE PRIVATE MAIN SYSTEM.
7. BACKFLOW PREVENTION AND CROSS-CONNECTION CONTROL SHALL COMPLY WITH 327IAC 8-10.

- NOTES:
1. EXISTING PAVEMENT IS TO BE SAW CUT FOR A CLEAN BREAK.
  2. TRENCH SPOIL IS TO BE REMOVED FROM THE WORK SITE.
  3. NEW SURFACE TO BE SLOPED AT SAME RATE AS THE EXISTING SURFACE.
  4. GRANULAR FILL SHALL BE PROVIDED WITHIN 5' OF PAVED SURFACE

**TYPICAL TRENCH DETAIL FOR D.I. AND PVC C900 PIPE 12" DIA. OR LESS IN PAVED AREAS**

NOT TO SCALE

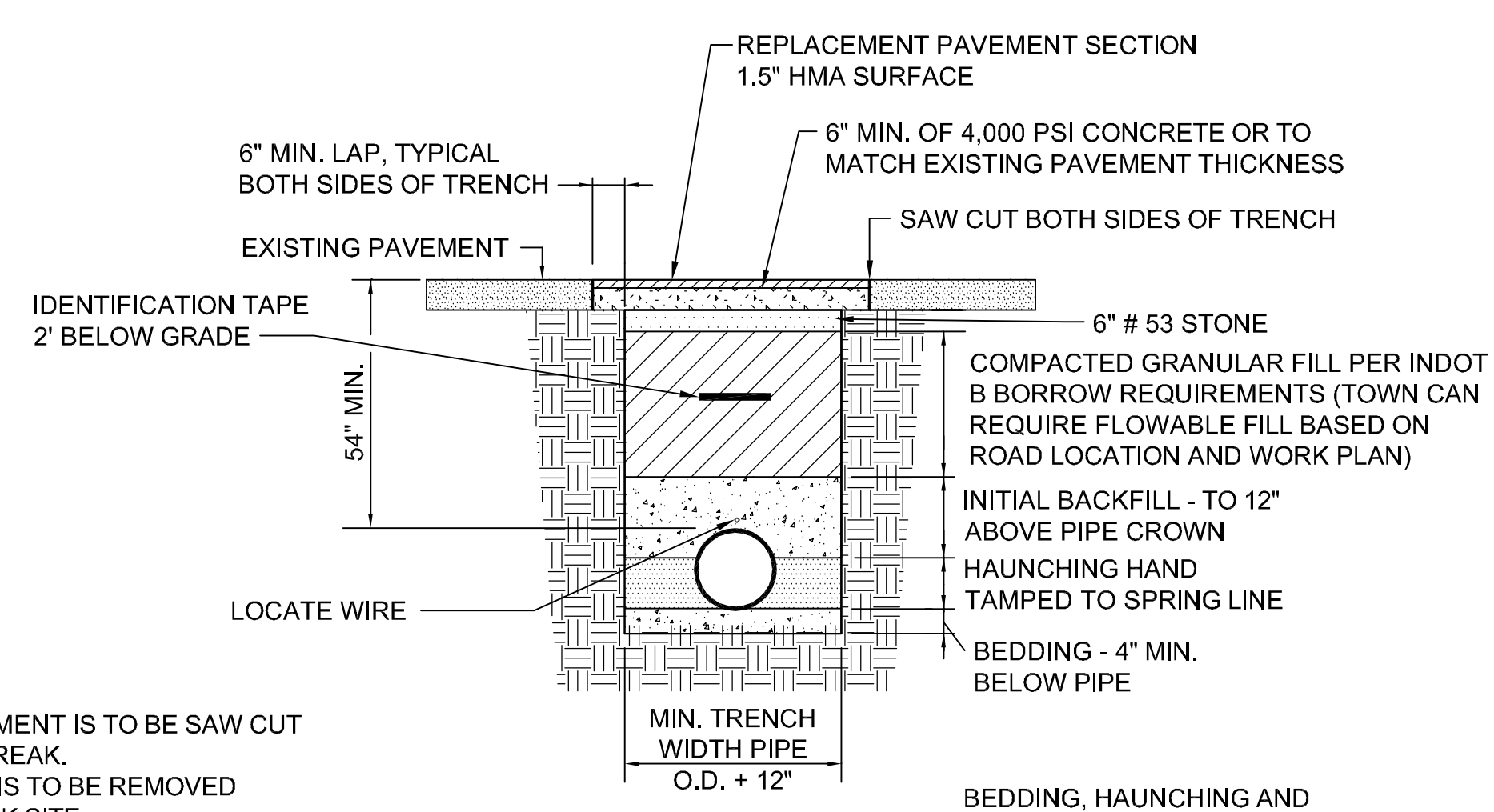

- NOTES:
1. EXISTING PAVEMENT IS TO BE SAW CUT FOR A CLEAN BREAK.
  2. TRENCH SPOIL IS TO BE REMOVED FROM THE WORK SITE.
  3. NEW SURFACE TO BE SLOPED AT SAME RATE AS THE EXISTING SURFACE.
  4. GRANULAR FILL SHALL BE PROVIDED WITHIN 5' OF PAVED SURFACE

**TYPICAL TRENCH DETAIL FOR D.I. OR PVC C905 PIPE LARGER THAN 12" DIA. IN PAVED AREAS**

NOT TO SCALE

**TYPICAL TRENCH DETAIL FOR D.I. OR PVC C900 PIPE 12" DIA. OR LESS IN UNPAVED AREAS**

NOT TO SCALE

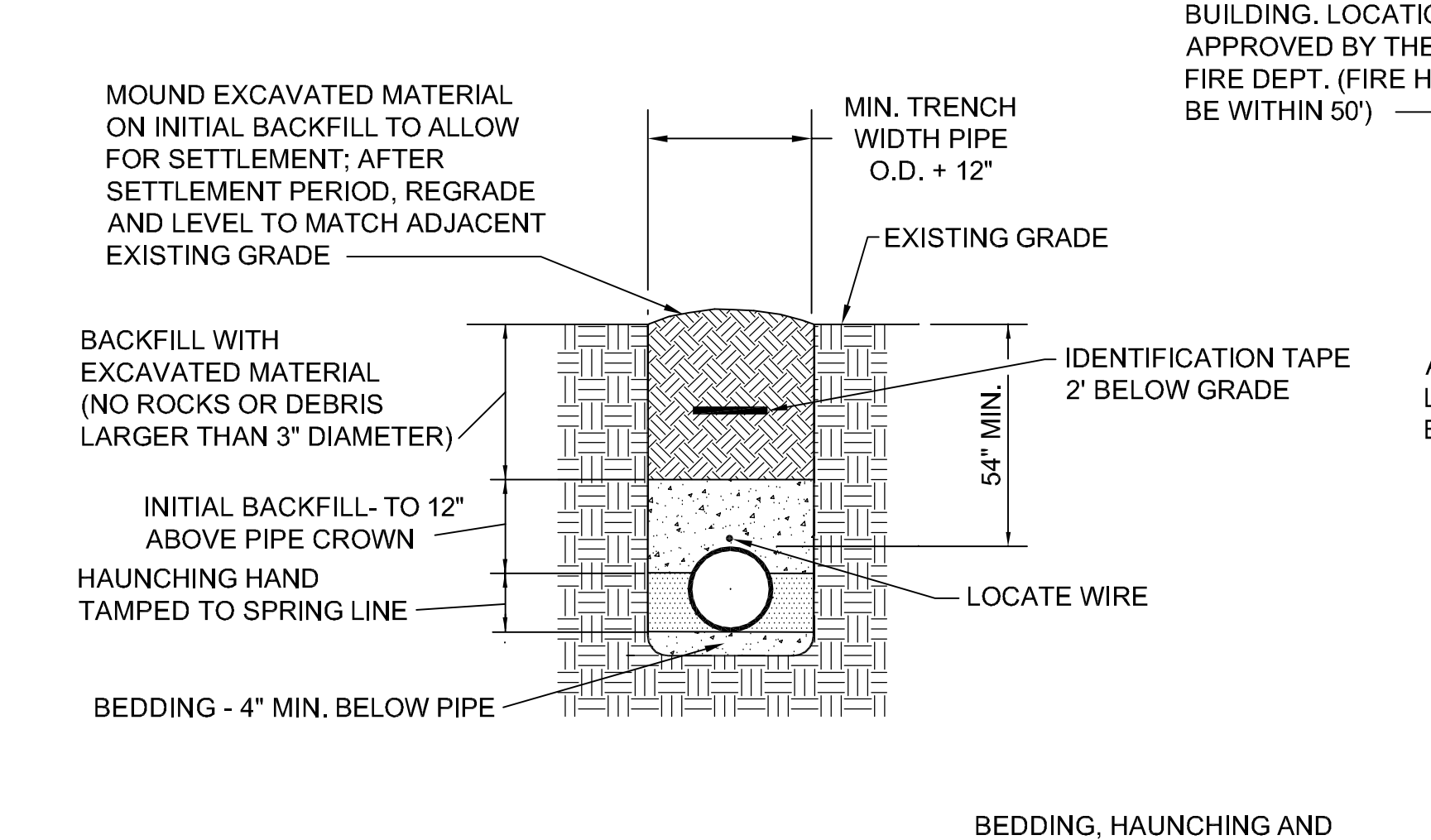

- NOTES:
1. EXISTING PAVEMENT IS TO BE SAW CUT FOR A CLEAN BREAK.
  2. TRENCH SPOIL IS TO BE REMOVED FROM THE WORK SITE.
  3. NEW SURFACE TO BE SLOPED AT SAME RATE AS THE EXISTING SURFACE.
  4. GRANULAR FILL SHALL BE PROVIDED WITHIN 5' OF PAVED SURFACE

**TYPICAL TRENCH DETAIL FOR D.I. OR PVC C905 PIPE LARGER THAN 12" DIA. IN UNPAVED AREAS**

NOT TO SCALE

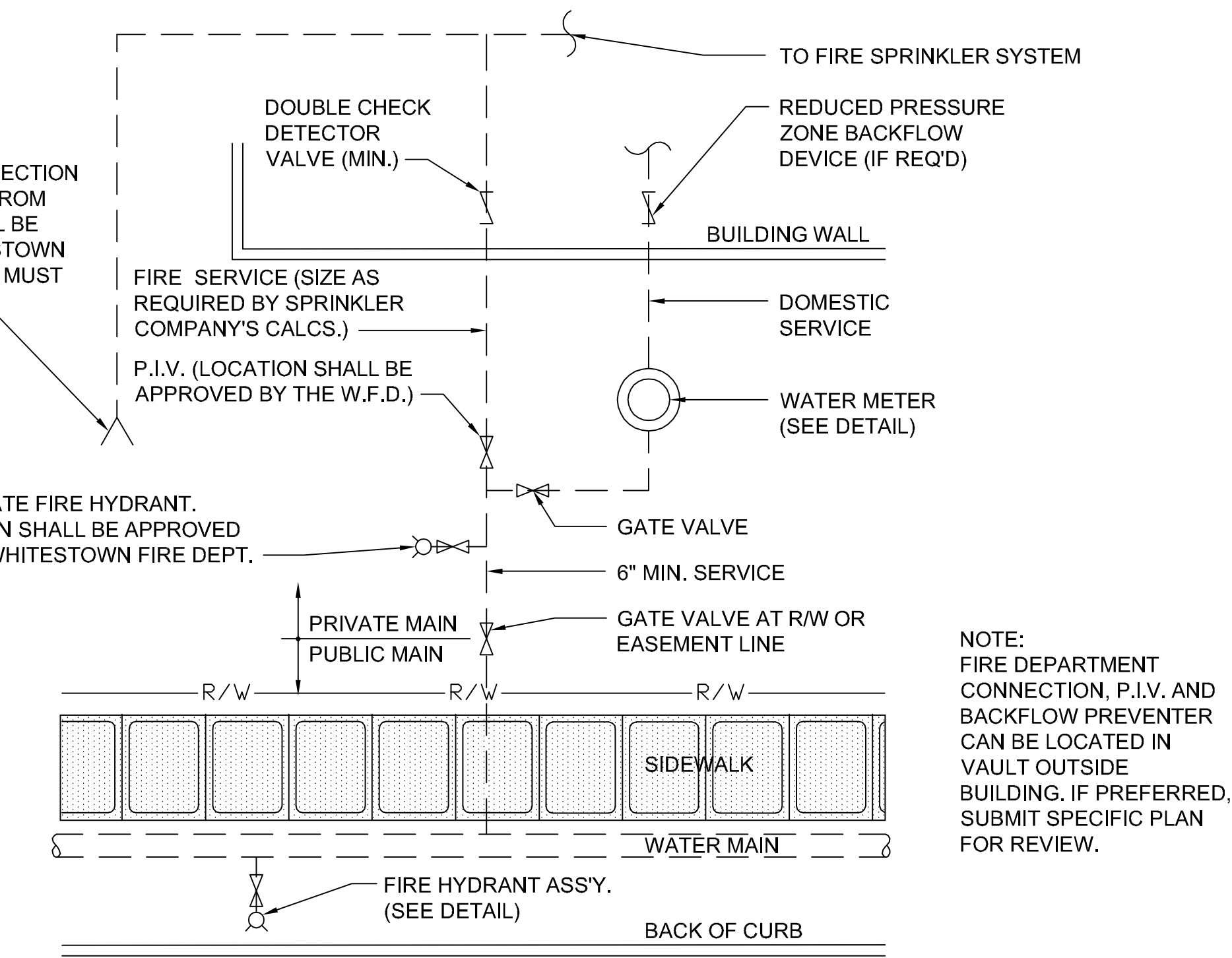

- NOTE:  
FIRE DEPARTMENT CONNECTION, P.I.V. AND BACKFLOW PREVENTER CAN BE LOCATED IN VAULT OUTSIDE BUILDING. IF PREFERRED, SUBMIT SPECIFIC PLAN FOR REVIEW.

**FIRE SERVICE CONNECTION DETAIL**

NOT TO SCALE

PRINTED: 7/30/2015 @ 2:48PM  
FILE NAME: L:\AutoCAD Resources\Info Sanitary\Clients\Standards\Whitestown - 120409\Details 2015\SHEET\_03\_WATER.dwg

NO.	DATE	BY	REVISIONS

SCALE: N.T.S.  
SHEET NO.

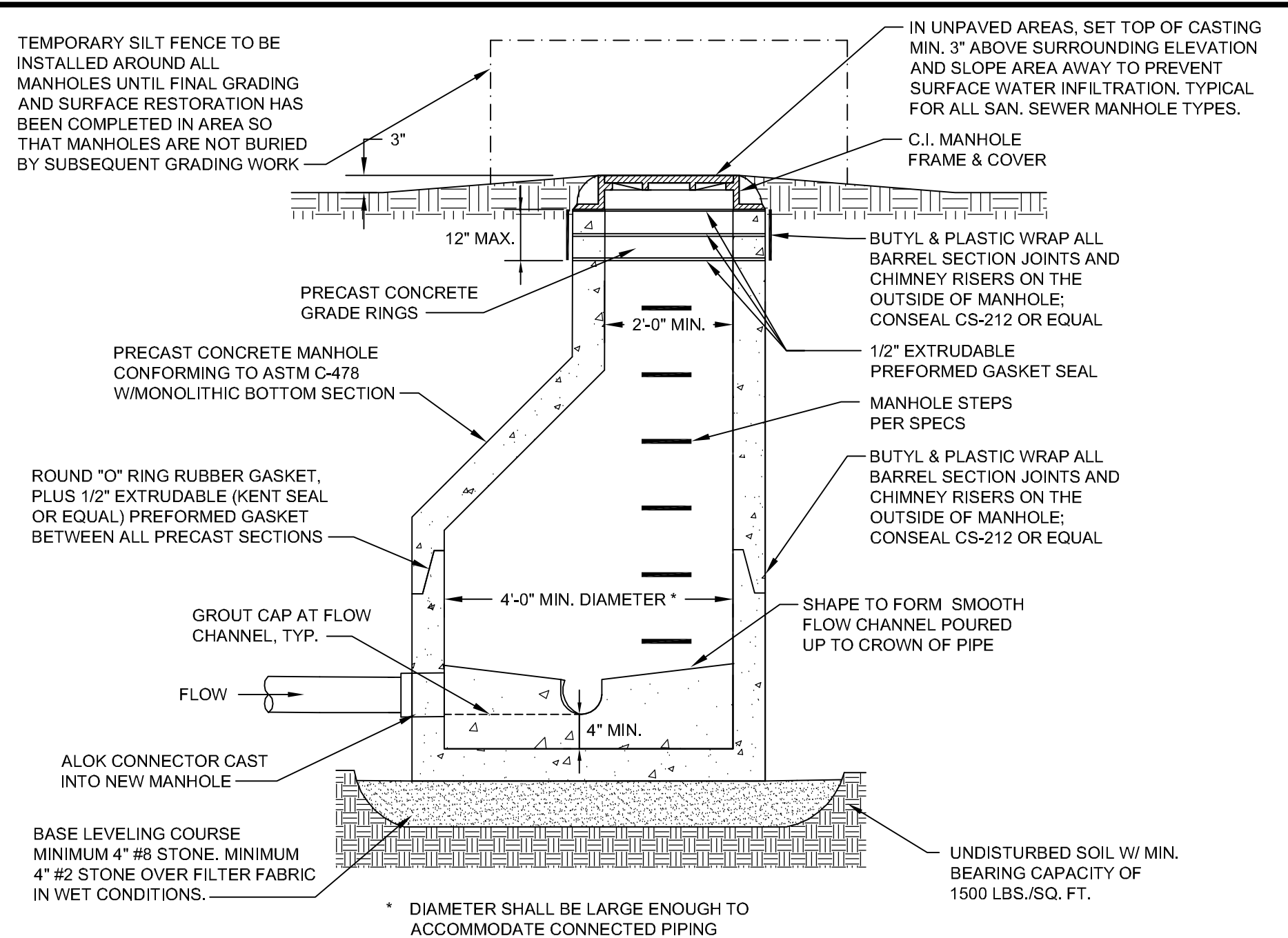

**TYPE "A" MANHOLE  
STANDARD PRECAST MANHOLE**  
NOT TO SCALE

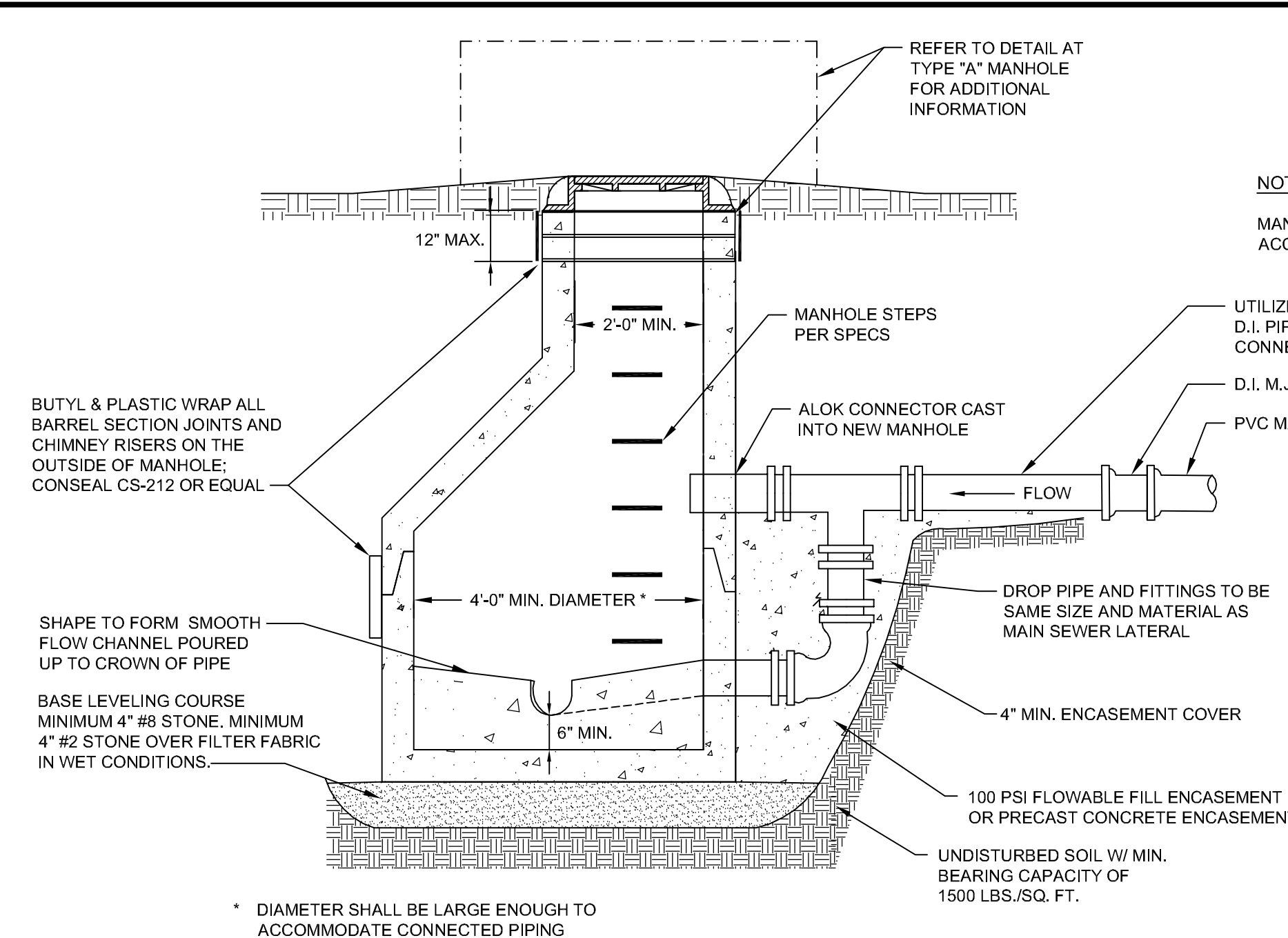

**TYPE "B" MANHOLE  
OUTSIDE DROP MANHOLE CONNECTION**  
NOT TO SCALE

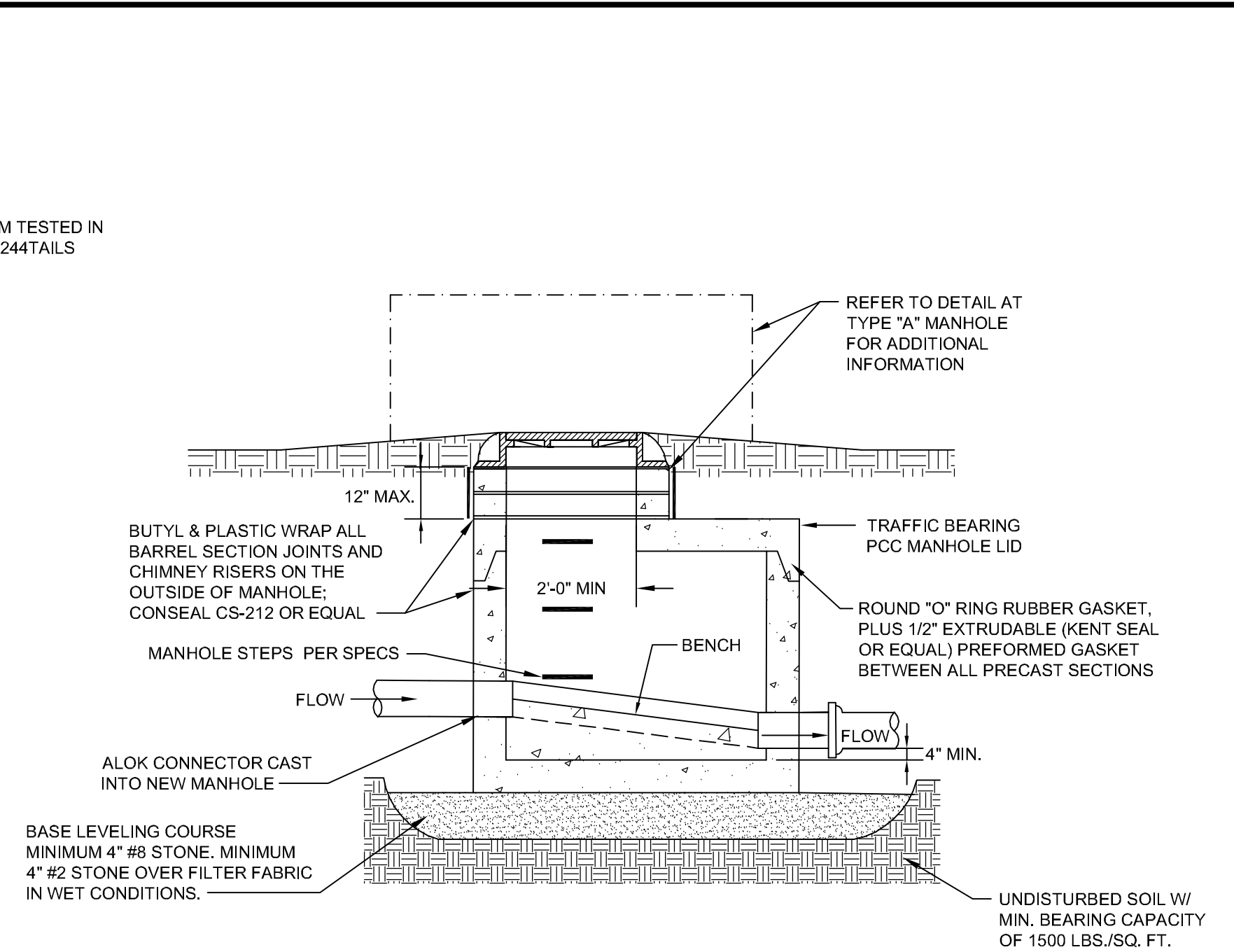

**TYPE "C" MANHOLE  
SHALLOW MANHOLE LESS THAN 5'**  
NOT TO SCALE

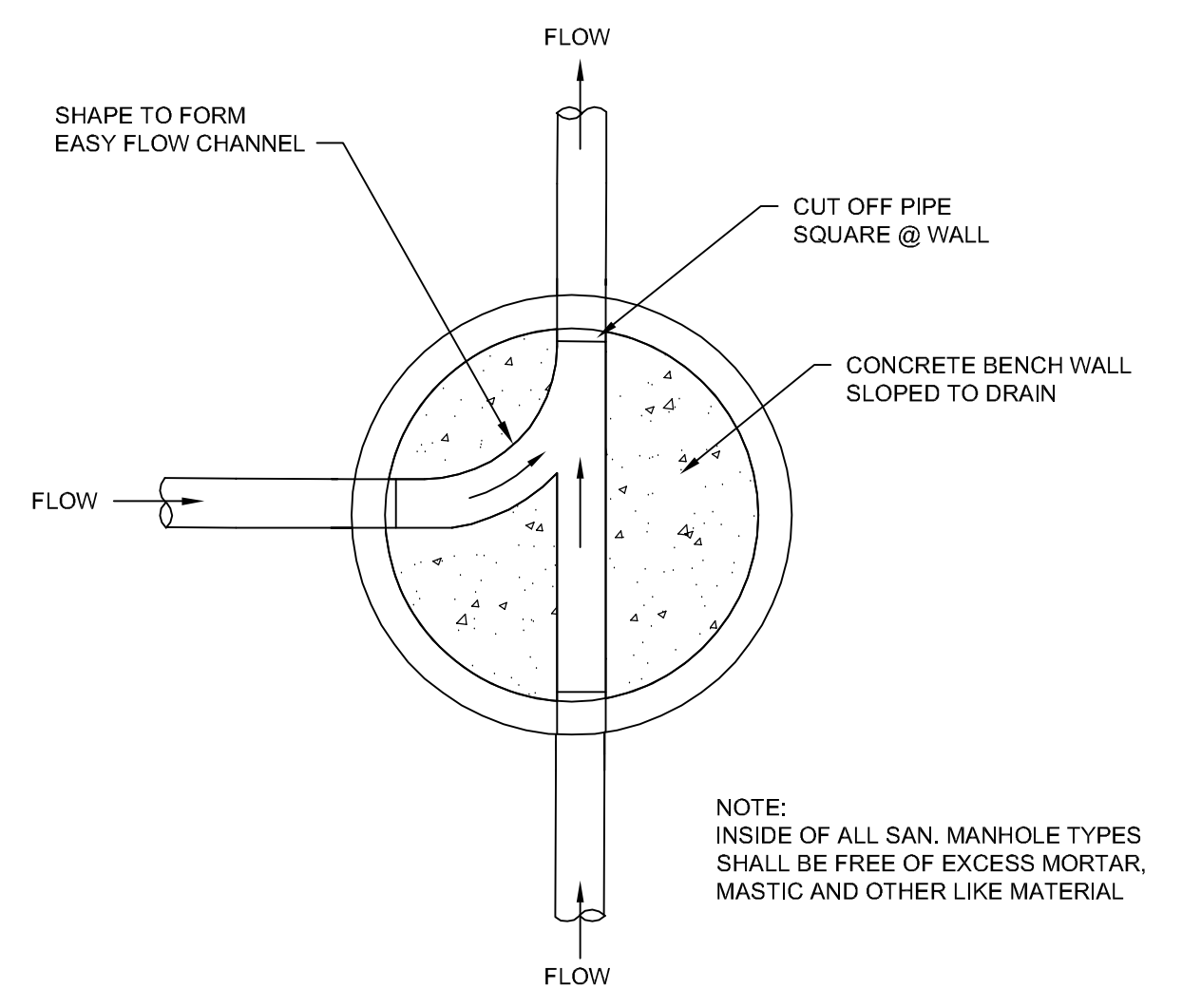

**STANDARD MANHOLE  
BENCH WALL**  
NOT TO SCALE

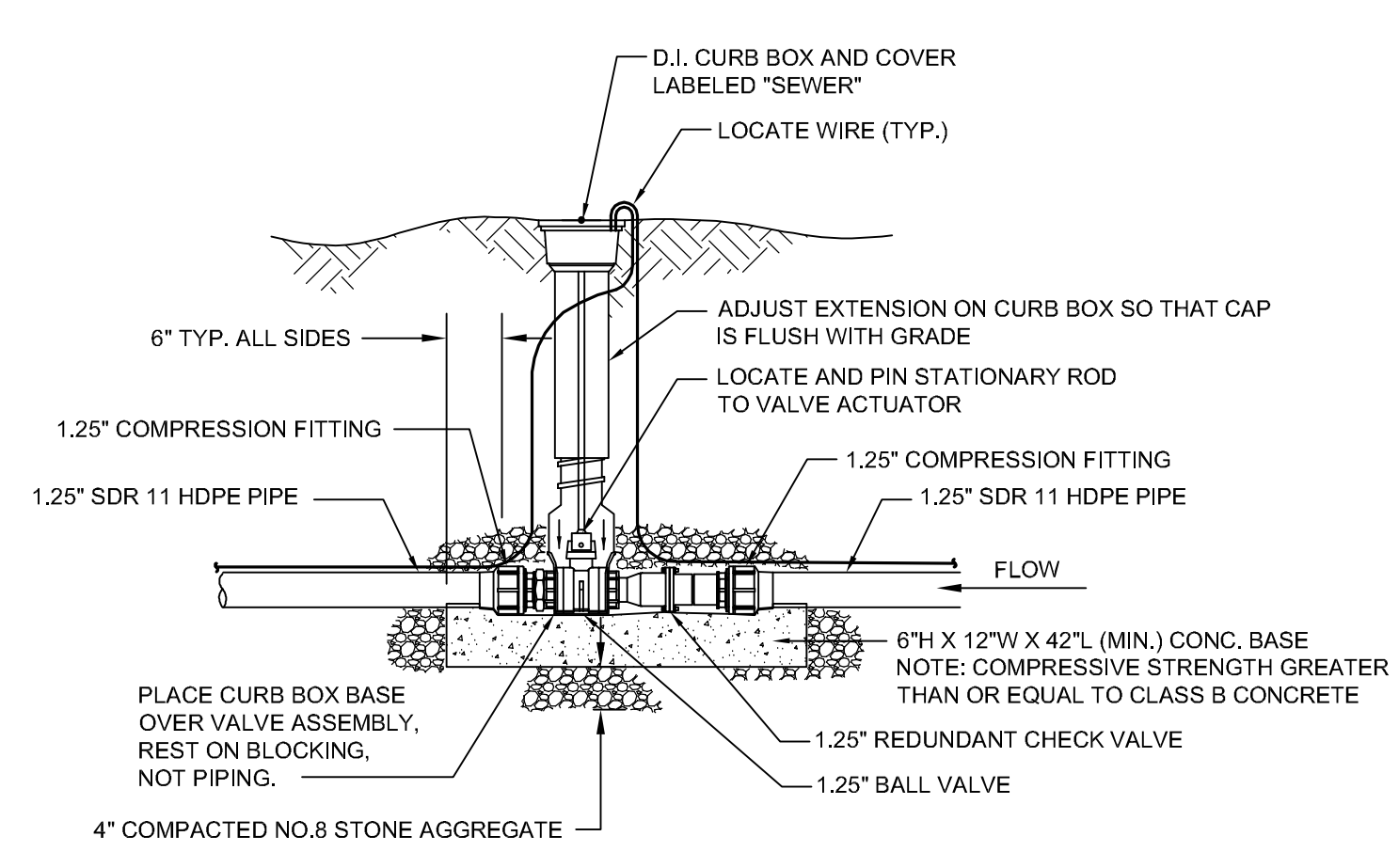

**CURB STOP ASSEMBLY DETAIL**  
NOT TO SCALE

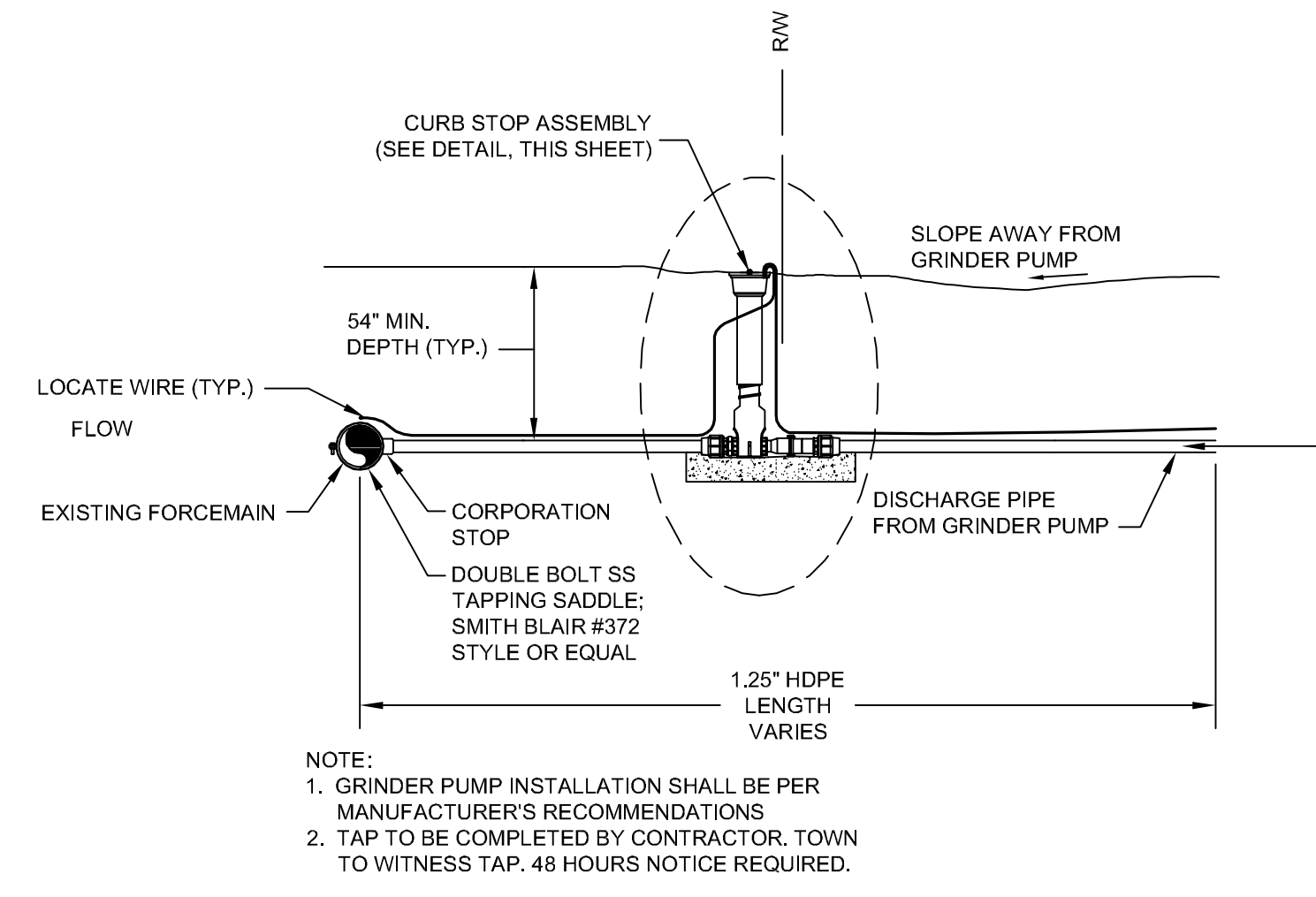

**GRINDER PUMP  
FORCEMAIN TAP DETAIL**  
NOT TO SCALE

**CASTING SCHEDULE**

NEENAH FOUNDRY COMPANY FRAME AND COVER R1772-C	EAST JORDAN IRON WORKS FRAME AND COVER 1022-3
---	--

"THE WORDS 'SANITARY SEWER' SHALL BE CAST INTO THE COVER WITH 2" LETTER HEIGHT, HEAVY DUTY, SOLID, AND THE COVER SHALL BE SELF SEALING WITH NON-PENETRATING PICK HOLES"

**TABLE OF STEEL CASING SIZES**

CASING DIAMETER IN INCHES	WALL THICKNESS (WITH PROTECTIVE COATING) IN INCHES	WALL THICKNESS (WITHOUT PROTECTIVE COATING) IN INCHES
12"	0.188"	0.250"
16"	0.219"	0.281"
18"	0.250"	0.312"
20"	0.281"	0.344"
24"	0.312"	0.375"
30"	0.406"	0.469"
36"	0.469"	0.532"

- NOTES**
- CASING SHALL BE WELDED STEEL PIPE, NEW AND UNUSED MATERIAL IN ACCORDANCE WITH ASTM A-139; MINIMUM YIELD STRENGTH = 35,000 PSI.
  - CASING SPACERS REQUIRED. MAXIMUM 10'-0" SPACING FOR DUCTILE IRON CARRIER PIPES. MAXIMUM SPACING FOR PVC CARRIER PIPES SHALL BE 6'-0". FOLLOW MANUFACTURER'S RECOMMENDATIONS FOR PLACEMENT AND SPACING.
  - THE INSIDE DIAMETER OF THE CASING SHALL BE A MINIMUM OF SIX (6) INCHES LARGER THAN THE LARGEST DIAMETER OF THE CARRIER PIPE JOINT.
  - THE ABOVE GIVEN CASING SIZES DO NOT APPLY TO RAILROAD CROSSINGS. CONTACT SPECIFIC RAILROAD FOR REQUIREMENTS.

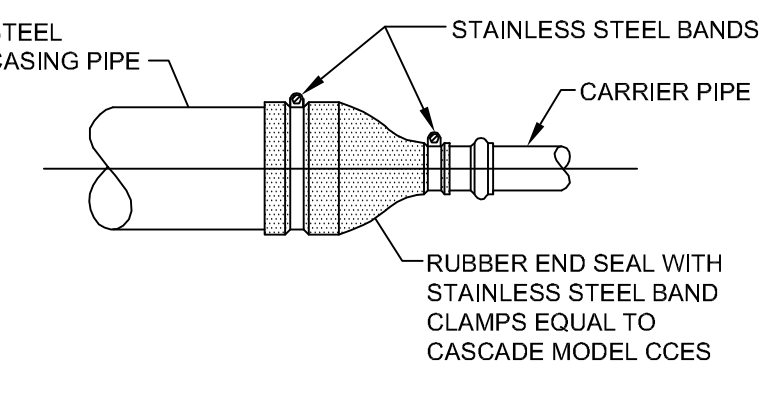

**CASING END SEAL DETAIL**  
NOT TO SCALE

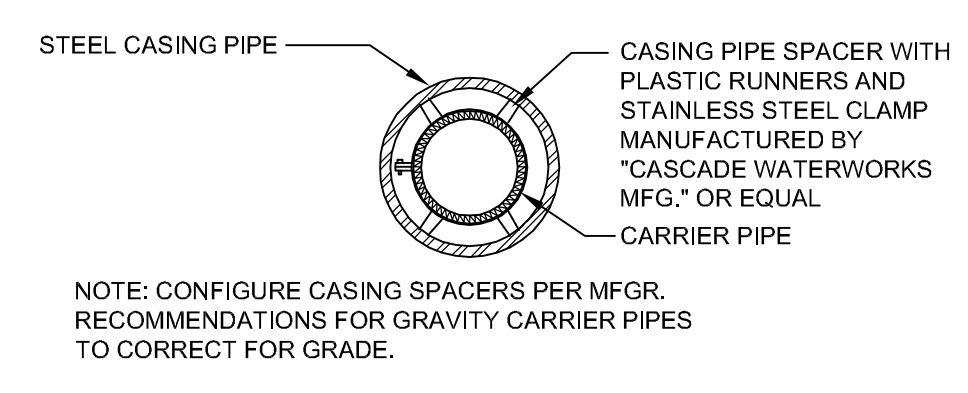

**CENTERING CARRIER PIPE WITH  
CASING SPACER (PRESSURE PIPES)**  
NOT TO SCALE

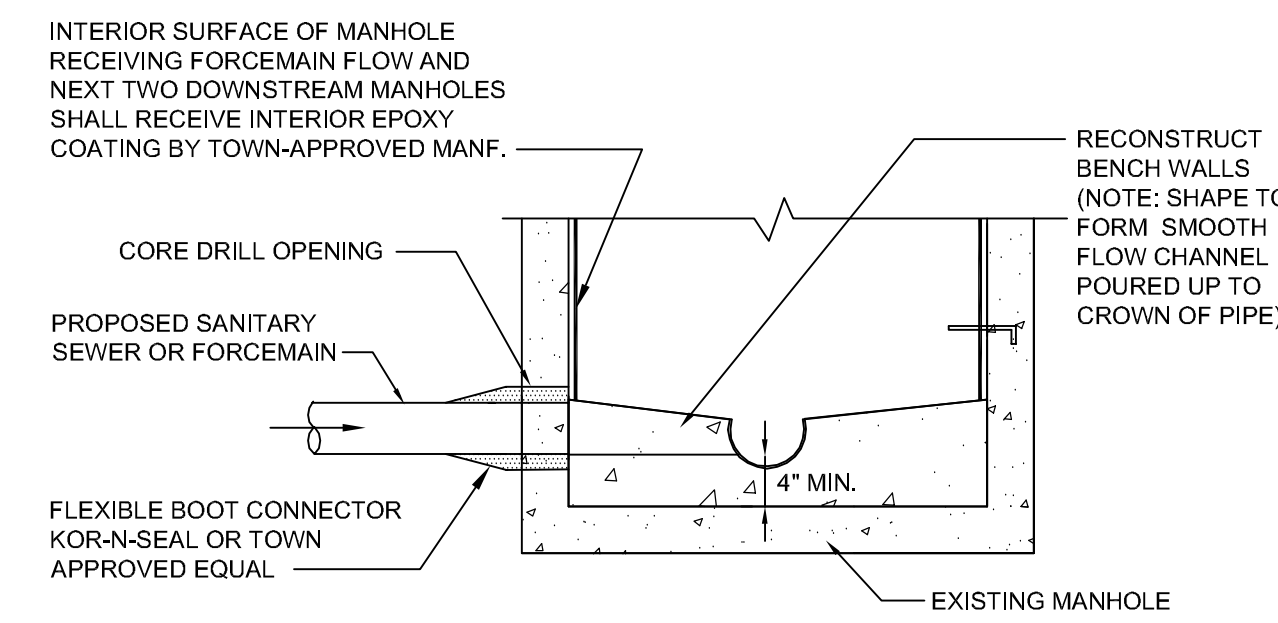

**EXISTING MANHOLE CONNECTION DETAIL**  
NOT TO SCALE

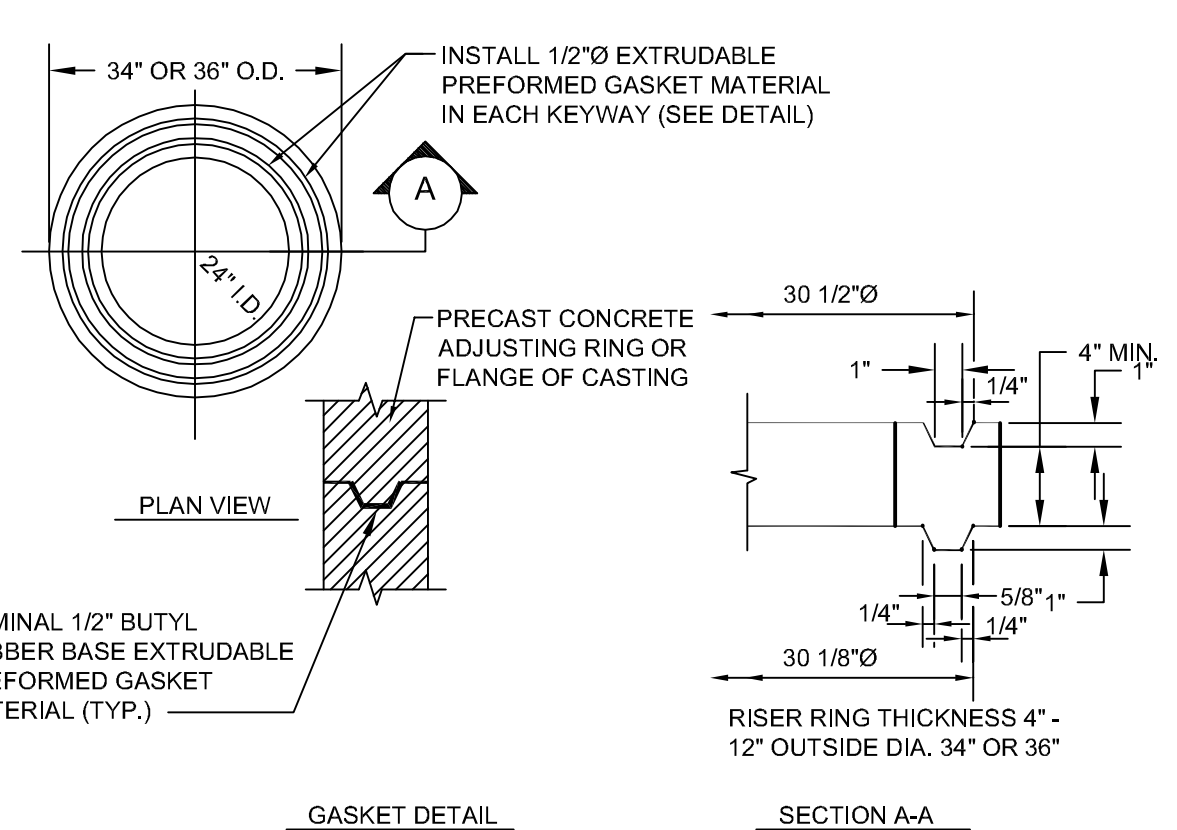

**PRECAST ADJUSTING RING**  
NOT TO SCALE

FILE NAME: L:\AutoCAD Resources\Info Sanitary\Client Standards\Whitestown - 120409\Details 2015\SHEET\_04\_SANSEWER.dwg PRINTED: 7/30/2015 @ 2:51 PM



TOWN OF WHITESTOWN  
STANDARD DETAILS FOR SANITARY SEWERS

NO.	DATE	DESCRIPTION

DATE: \_\_\_\_\_  
SCALE: N.T.S.  
SHEET NO. **5**

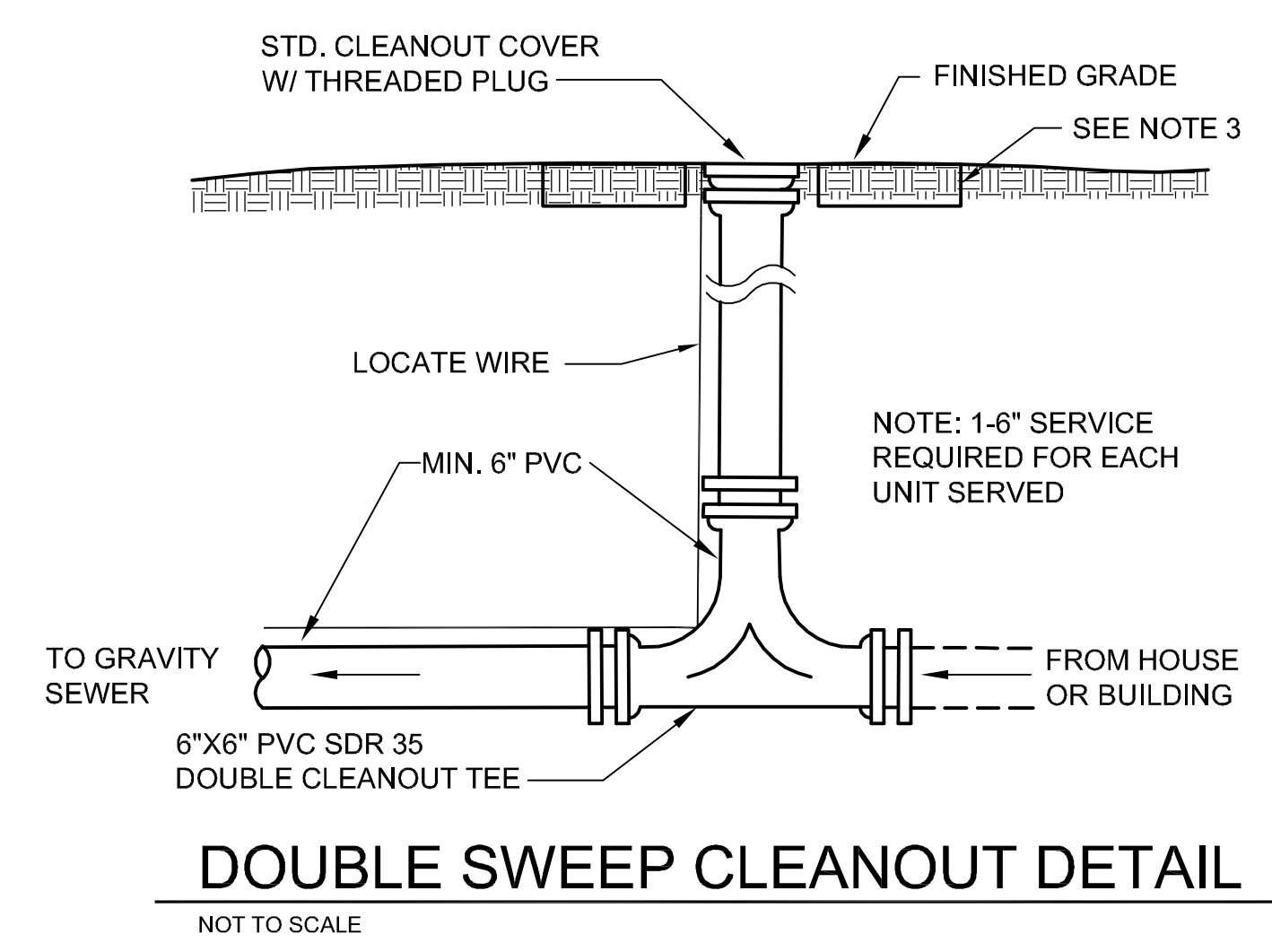

**GENERAL NOTES FOR CLEANOUTS:**

- CLEANOUTS SHALL BE INSTALLED NO MORE THAN A MAX. 10'-0" FROM OUTSIDE FACE OF BUILDING FOUNDATION WALL AND EVERY 100'-0" MAX. THEREAFTER OR WHERE SERVICE LATERAL CHANGES DIRECTION BEFORE REACHING MAIN SANITARY SEWER LINE.
- CLEANOUT PLUGS SHALL NOT BE COVERED WITH CEMENT PLASTER, OR ANY OTHER PERMANENT FINISHING MATERIAL, WHERE IT IS NECESSARY TO CONCEAL A CLEAN OUT PLUG, A COVERING PLATE OR ACCESS DOOR SHALL BE PROVIDED WHICH WILL PERMIT READY ACCESS TO THE PLUG.
- ON COMMERCIAL AND INDUSTRIAL INSTALLATIONS A 2 FT. X 2 FT. X 4 IN. THICK CONCRETE PAD WITH CAST IRON CLEANOUT COVER (NEENAH R1974 OR EQUAL) SHALL BE PROVIDED AT GRADE IN BOTH PAVED AND UNPAVED AREAS. THE STANDARD PVC THREADED PLUG SHALL BE PROVIDED BELOW THE CAST IRON LID.

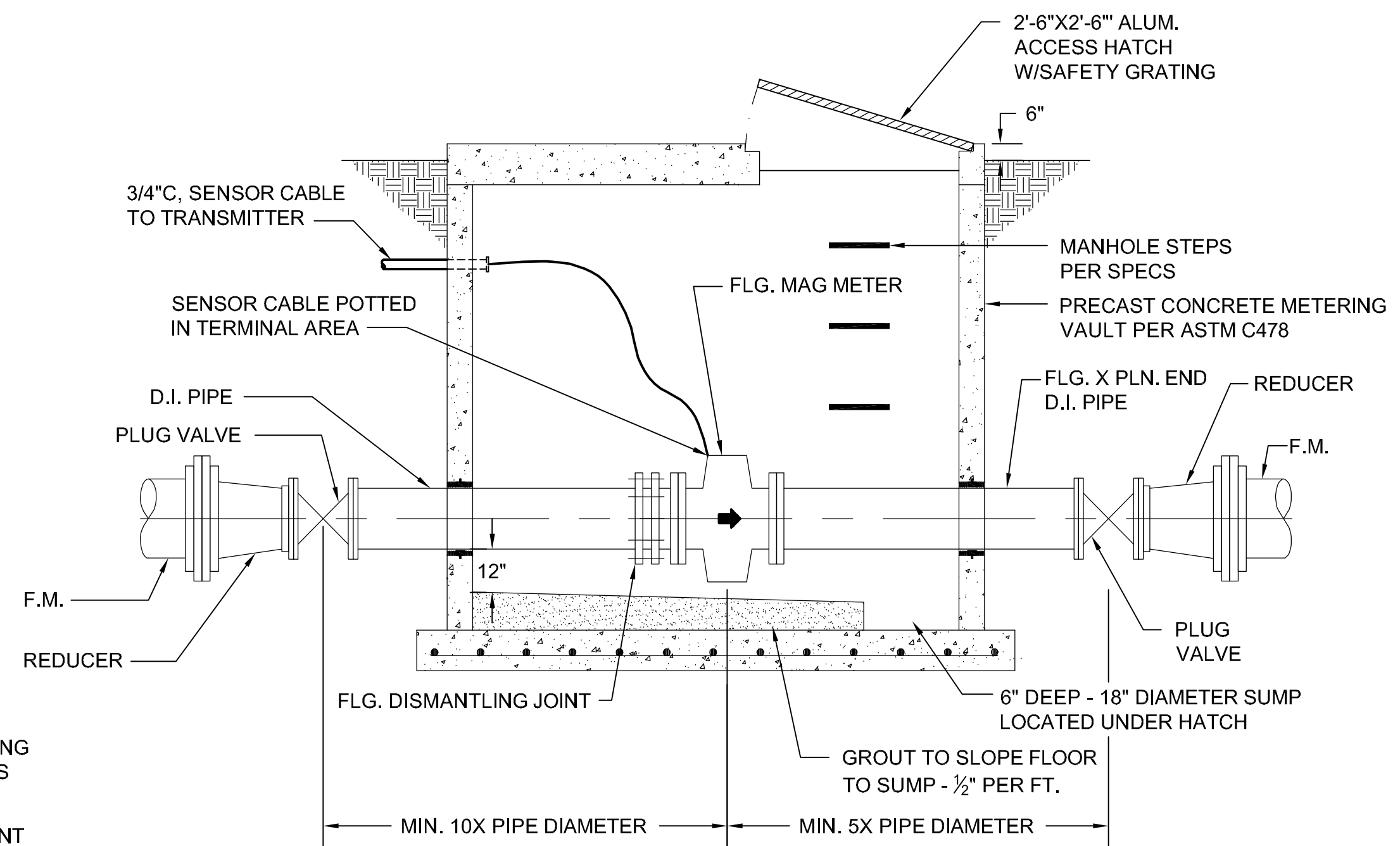

**FLOW METER NOTES:**

- METER REQUIRED ON LIFT STATION DISCHARGES. DETAILS TO BE COORDINATED AND APPROVED WITH TOWN. SEE SHEETS 9 AND 10 FOR LIFT STATION DETAILS.
- CONTRACTOR SHALL INSTALL MAG METER AND FORCEMAIN IN A MANNER TO ENSURE FULL PIPE FLOW/SUBMERGENCE AT ALL TIMES FOR PROPER MAG METER OPERATION.
- PROVIDE A SPOOL PIECE TO REPLACE MAGMETER BODY IF REMOVAL IS REQUIRED FOR REPAIR/REPLACEMENT.
- CONTRACTOR SHALL INSTALL MAG METER VAULT IN A MANNER TO ENSURE THAT A MINIMUM DISTANCE OF 10 PIPE DIAMETER UP STREAM AND 5 PIPE DIAMETER DOWN STREAM OF THE MAG METER IS FREE FROM BENDS AND OTHER APPURTANCES.

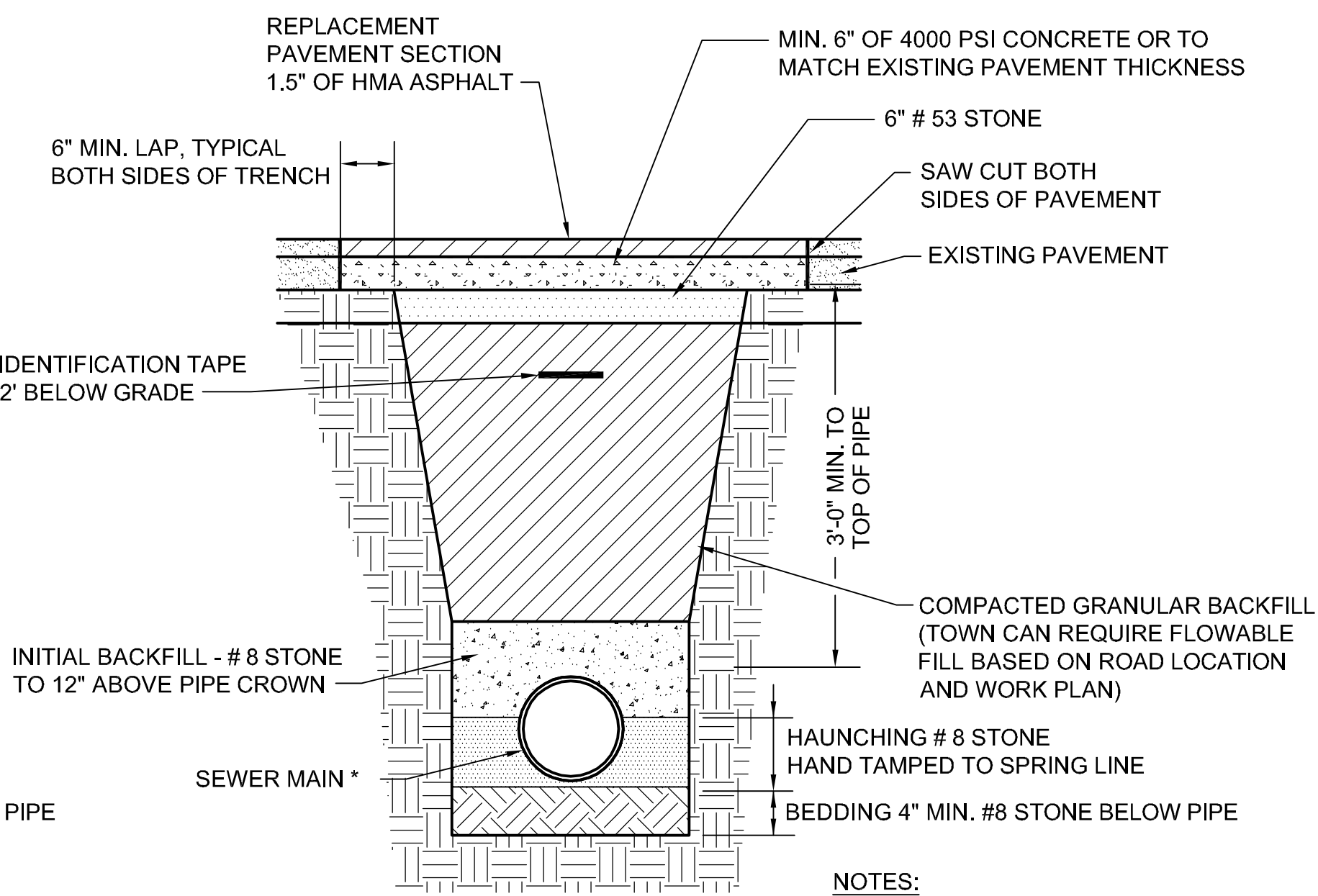
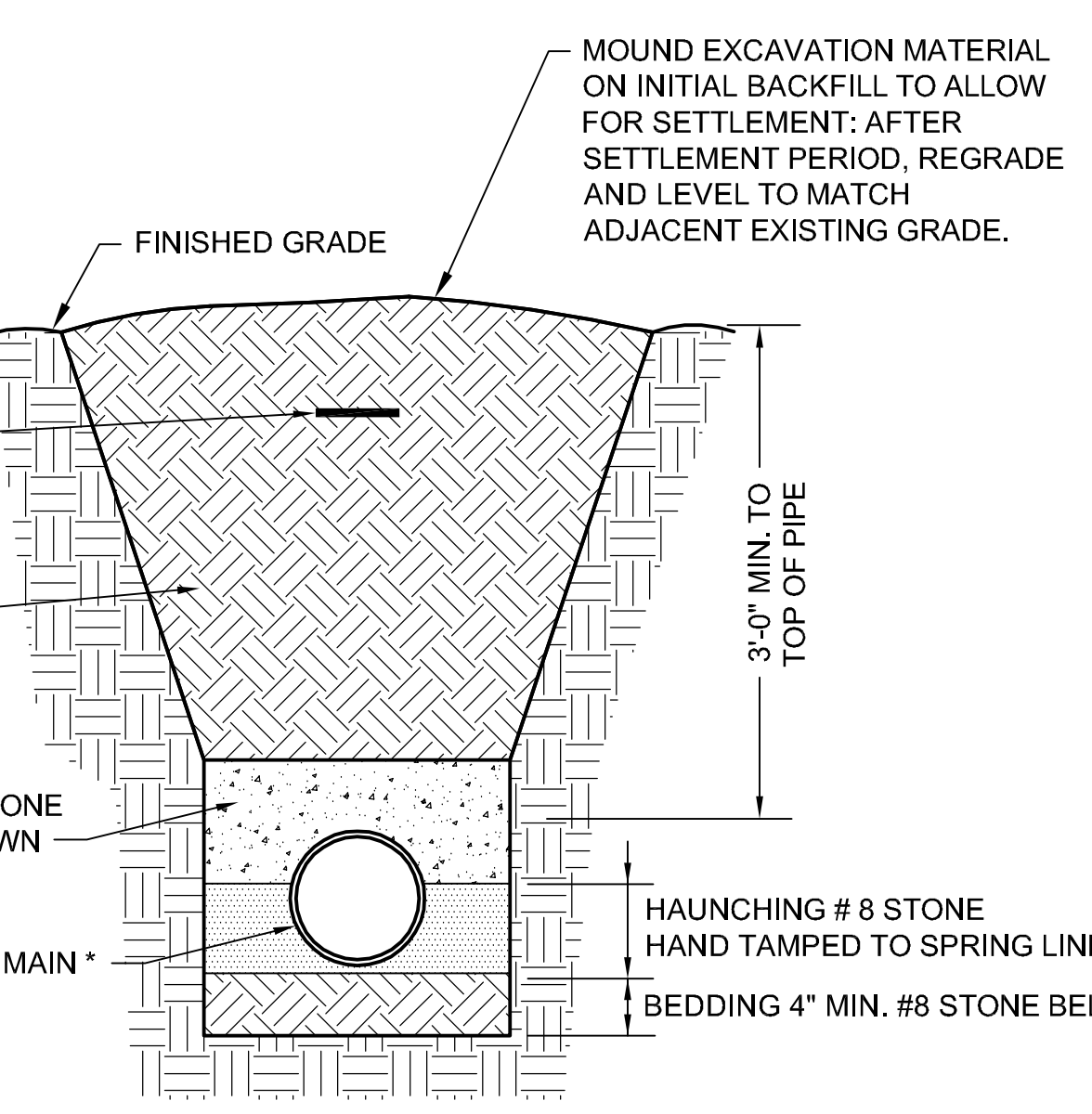
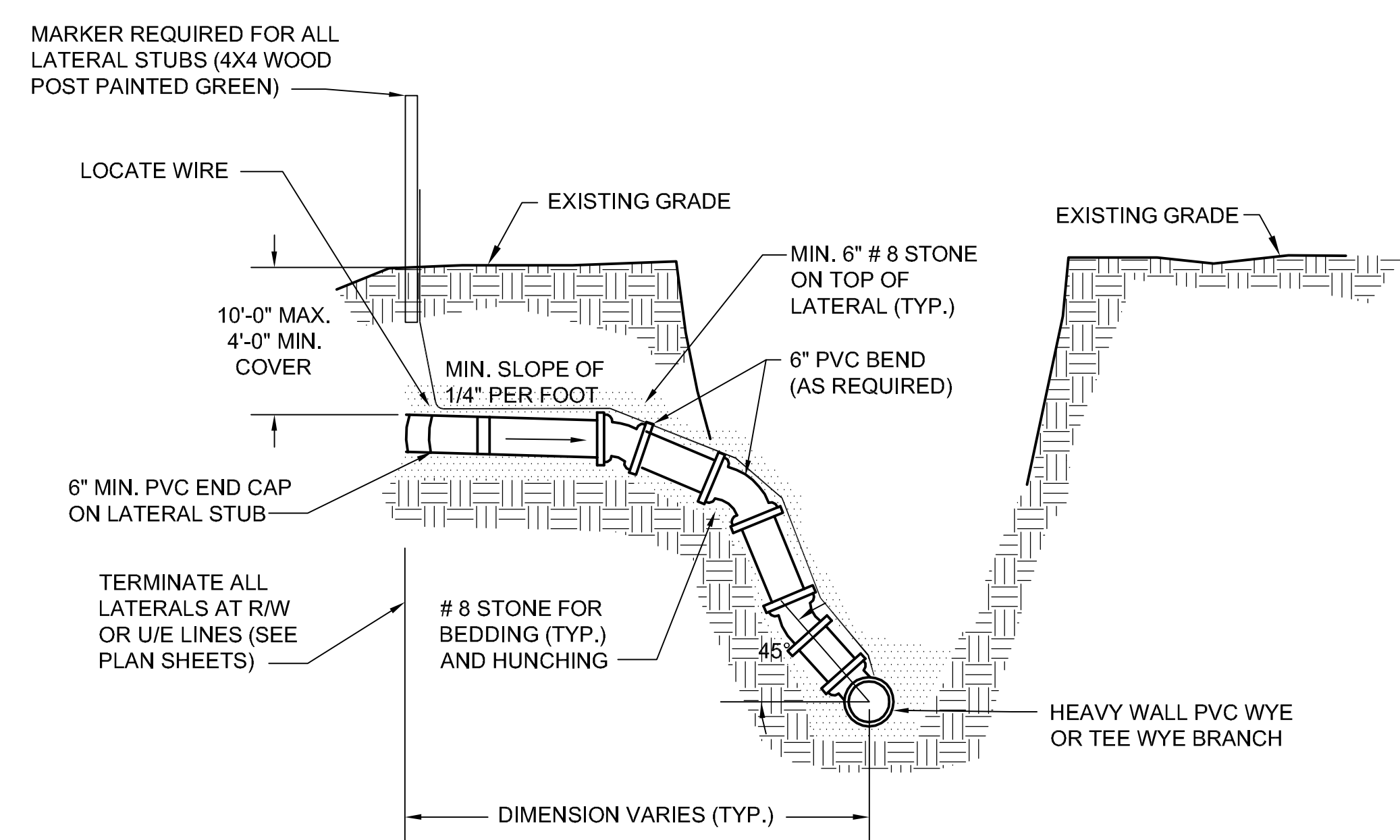
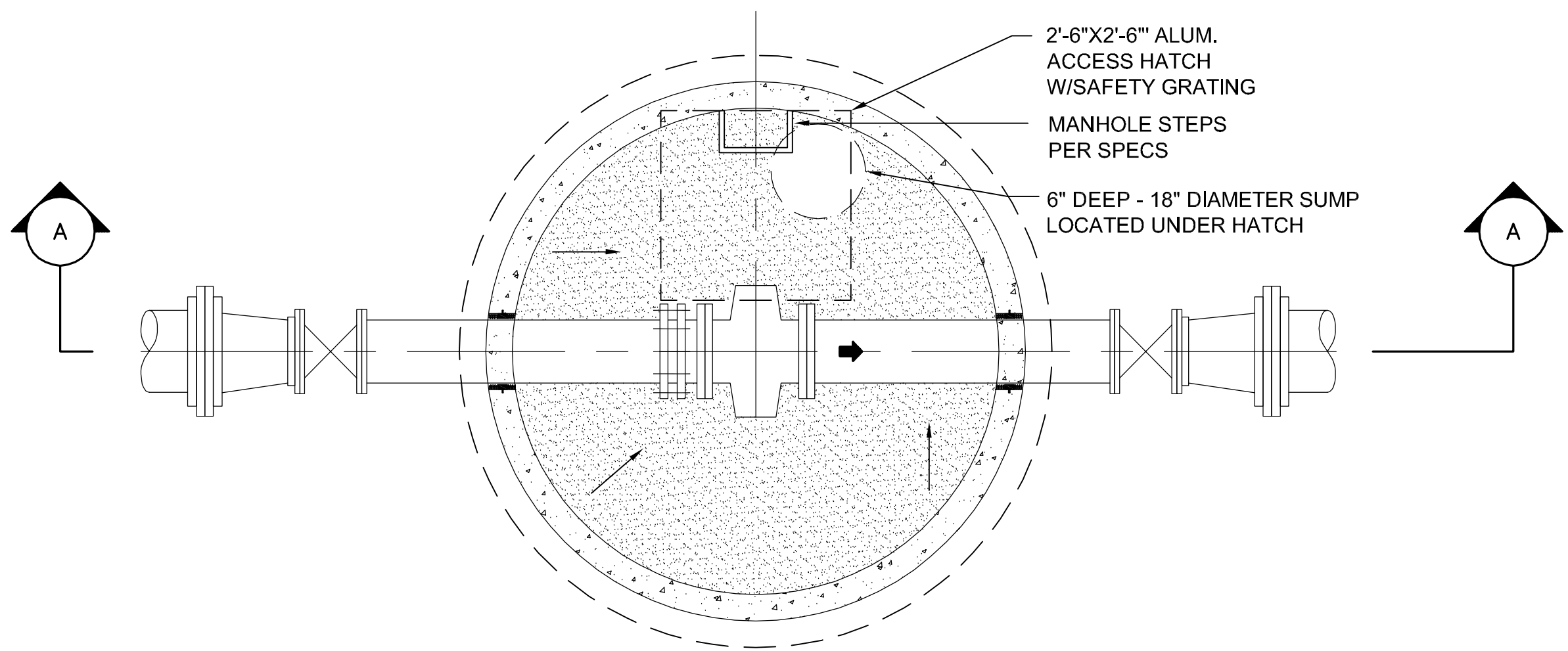

NOTE:  
FORCEMAINS ARE TO BE INSTALLED PER THE TYPICAL TRENCH DETAILS FOR WATER MAINS (SEE SHEET 3)

\* SDR 26 OR DUCTILE IRON USED FOR SEWER DEEPER THAN 15'.

- NOTES:**
- EXISTING PAVEMENT IS TO BE SAW CUT FOR A CLEAN BREAK.
  - TRENCH SPOIL IS TO BE REMOVED FROM THE WORK SITE.
  - NEW SURFACE TO BE SLOPED AT SAME RATE AS THE EXISTING SURFACE.
  - GRANULAR FILL TO BE USED WITHIN 5' OF ALL PAVED AREAS.

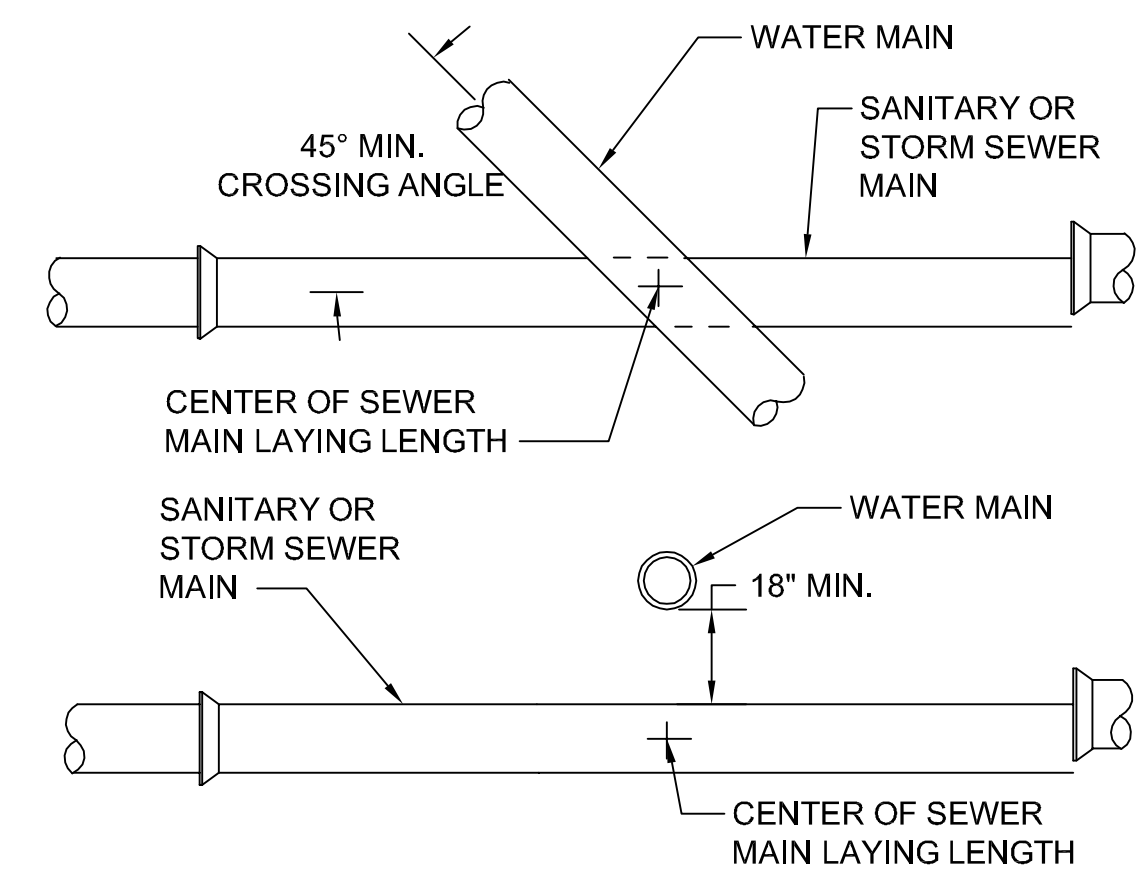

WATER MAIN AND SEWER MINIMUM SEPARATION:  
18" VERTICAL SEPARATION  
10'-0" HORIZONTAL SEPARATION

WATER MAIN QUALITY PIPE TO BE USED FOR SANITARY OR STORM SEWER IF REQUIRED SEPARATION CANNOT BE MET

PRINTED: 7/30/2015 @ 2:55PM  
FILE NAME: L:\AutoCAD Resources\Info Sanitary\Client\Standards\Whitestown - 120409\Details 2015\SHEET\_05\_SANSEWER.dwg

NO.	REVISIONS	DATE	BY

SCALE: N.T.S.

NOTES:

- GREASE TRAP SHALL CONFORM TO ASTM 858 UTILIZING 4000 PSI CONCRETE. STRUCTURE SHALL BE DESIGNED TO SUPPORT LOADING IN PLANNED LOCATION.
- EXTERIOR INSTALLATION MUST BE CONCRETE. STEEL GREASE TRAPS SHALL ONLY BE INSTALLED INSIDE BUILDING.
- CONTRACTOR MAY SUPPLY GREASE TRAP AS MANUFACTURED BY ZURN SERIES Z-1170 OR JAY R. SMITH MANUFACTURING COMPANY SERIES 8000 IF INTERIOR INSTALLATION UTILIZED.
- GREASE TRAPS MUST BE SIZED ACCORDING TO THE INDIANA STATE BOARD OF HEALTH BULLETIN S.E. 13, "ON-SITE WATER SUPPLY AND WASTEWATER DISPOSAL FOR PUBLIC AND COMMERCIAL ESTABLISHMENTS" SECTION 501 "GREASE TRAPS" AND PER LOCAL REQUIREMENTS OR CODES. THE SIZING METHOD FOR ALL STRUCTURES MUST BE APPROVED BY THE TOWN.
- SHOP DRAWINGS MUST BE SUBMITTED TO THE UTILITY ENGINEER FOR REVIEW AND APPROVAL.
- TOP OF CASTING SHALL EXTEND 3" MIN. ABOVE FINISHED GRADE.
- SAMPLE BOX SHALL BE PER TOWN STANDARDS.
- INTERIOR PIPING SHALL BE 6" (MIN.) PVC.

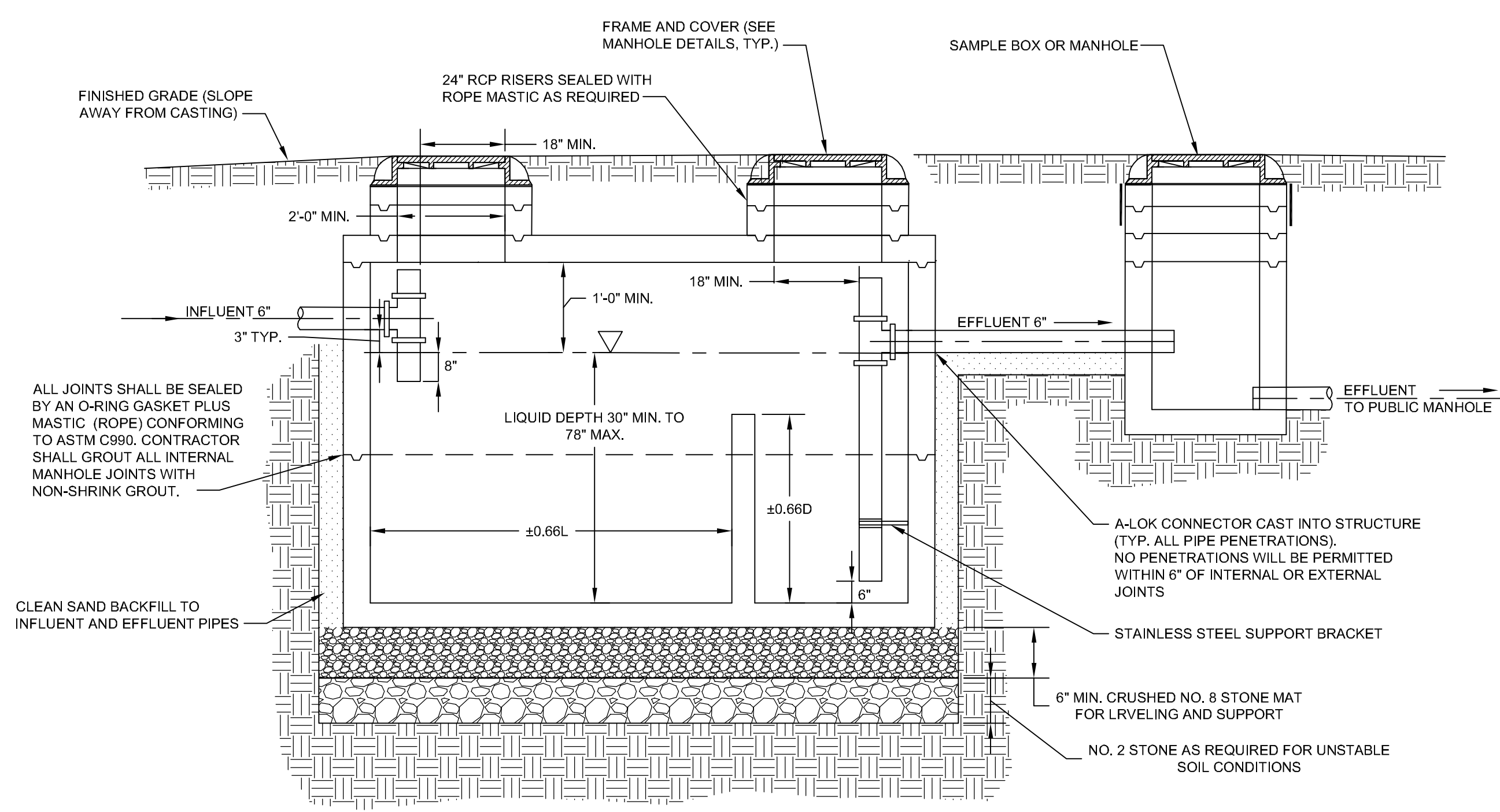

GREASE TRAP DETAIL  
NOT TO SCALE

STANDARD MANHOLE CASTING SET RIM 3" ABOVE GRADE AND SLOPE SURROUNDING AREA TO DRAIN AWAY FROM CASTING IN UNPAVED AREAS. SET FLUSH TO PAVEMENT IN PAVED AREAS.

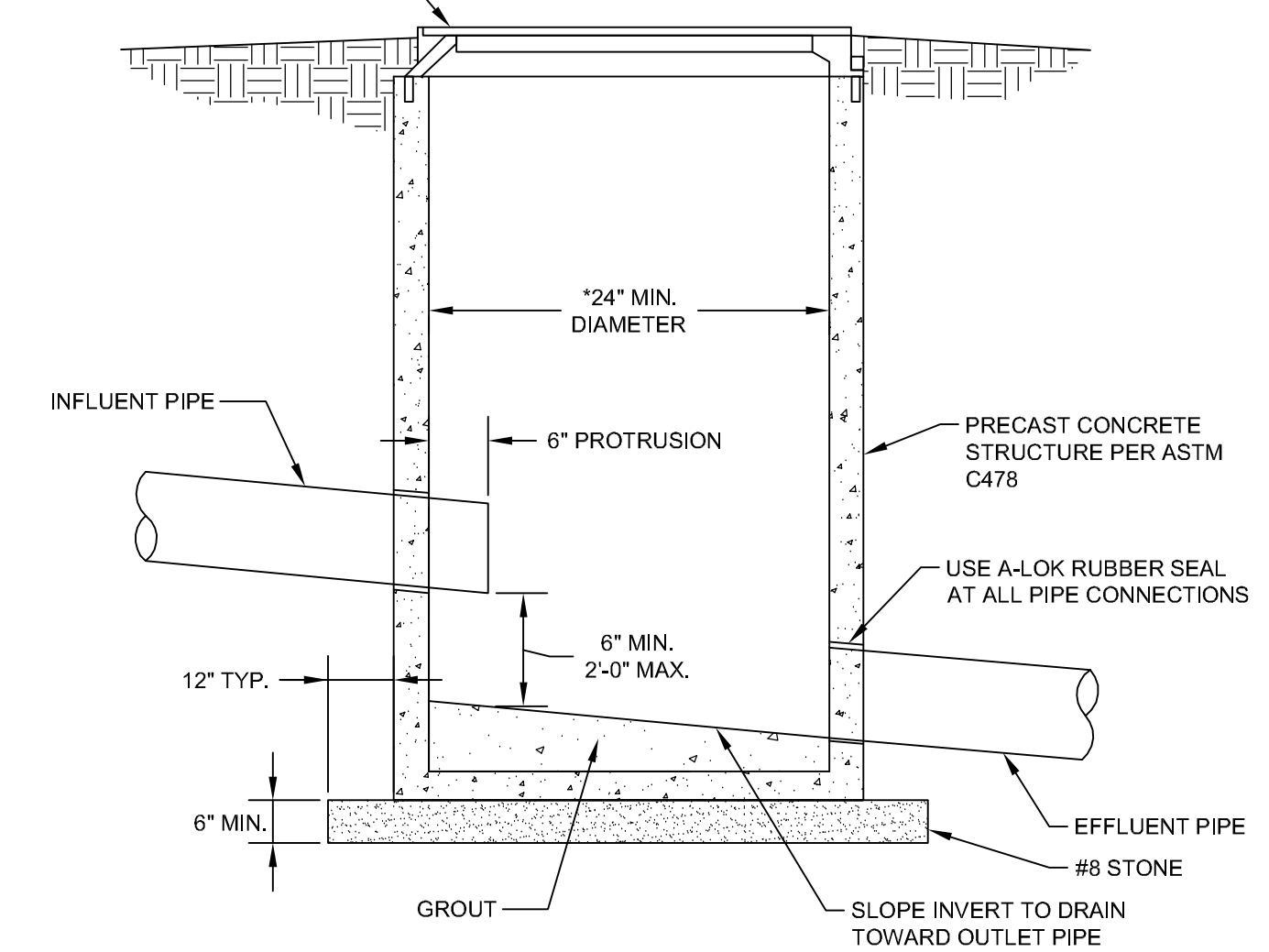

\*NOTE: WHERE DEPTH OF STRUCTURES EXCEEDS 4'-0", A 4FT. DIAMETER MANHOLE SHALL BE PROVIDED. THE PIPING CONFIGURATION SHALL BE THE SAME. MANHOLE STEPS SHALL BE INCLUDED.

SAMPLE STATION MANHOLE INSTALLATION DETAIL  
NOT TO SCALE

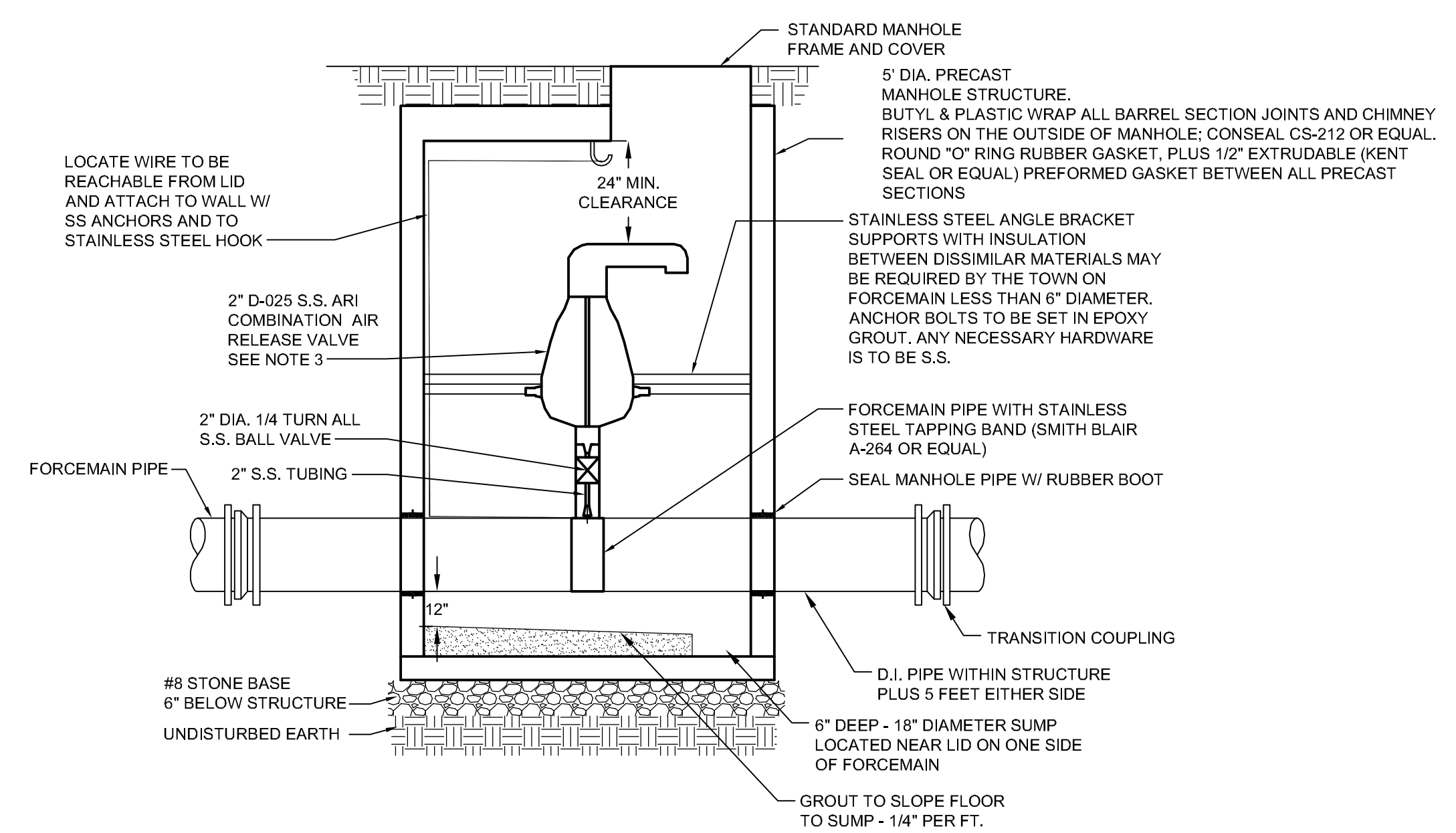

- NOTES:
- IF MORE THAN ONE AIR RELEASE VALVE IS INSTALLED WITH A FORCEMAIN, THE DEVELOPER SHALL PROVIDE ONE SPARE AIR RELEASE VALVE TO THE TOWN OF WHITESTOWN.
  - AIR RELEASE VALVES MUST BE INSTALLED AT ALL HIGH SPOTS IN PRESSURE PIPE.
  - THE DESIGN ENGINEER SHALL VERIFY ARI SIZING REQUIRED FOR THE FORCE MAIN SYSTEM BEING PLANNED.

AIR RELEASE VALVE VAULT DETAIL  
NOT TO SCALE

NO.	REVISIONS	DATE	BY

DATE:	
SCALE:	N.T.S
SHEET NO.	7

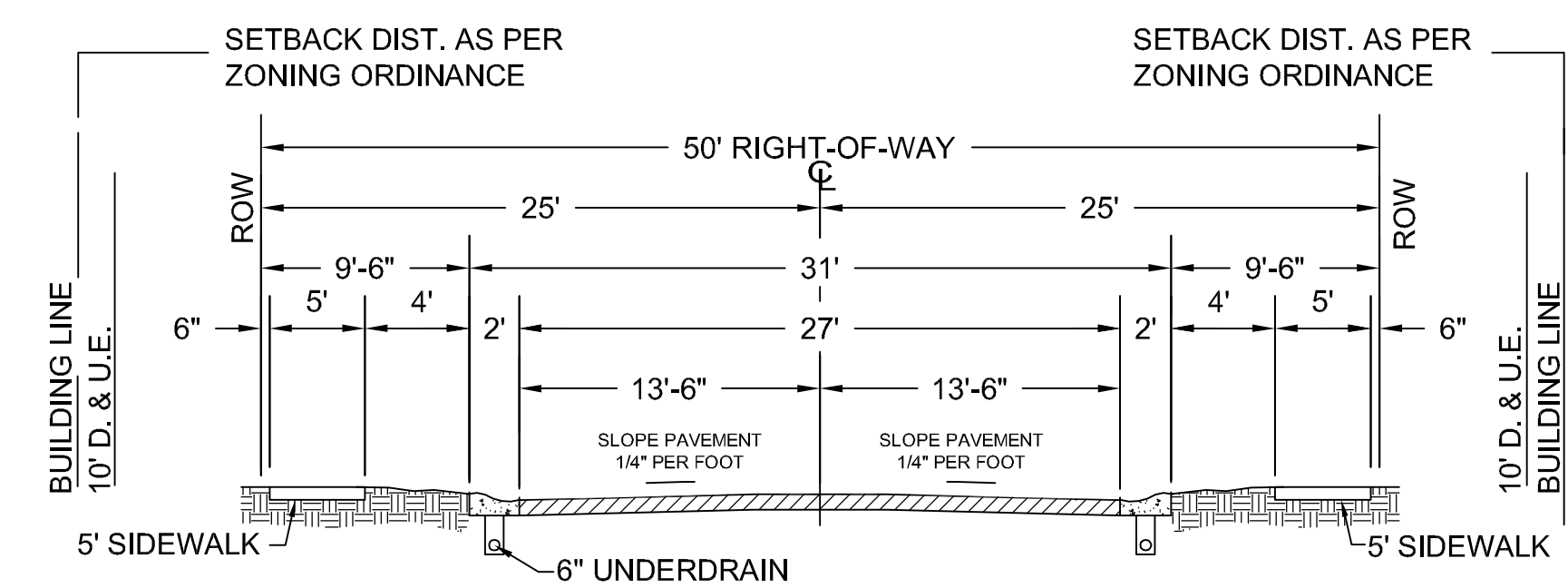

NOTE:  
TWO 13'-6" MOVING LANES WITH NO PARKING LANE AS SHOWN ABOVE.  
ALTERNATIVE, TWO 11'-0" MOVING LANES WITH ONE 8'-0" PARKING LANE.

**LOCAL STREET OR CUL-DE-SAC**

NOT TO SCALE

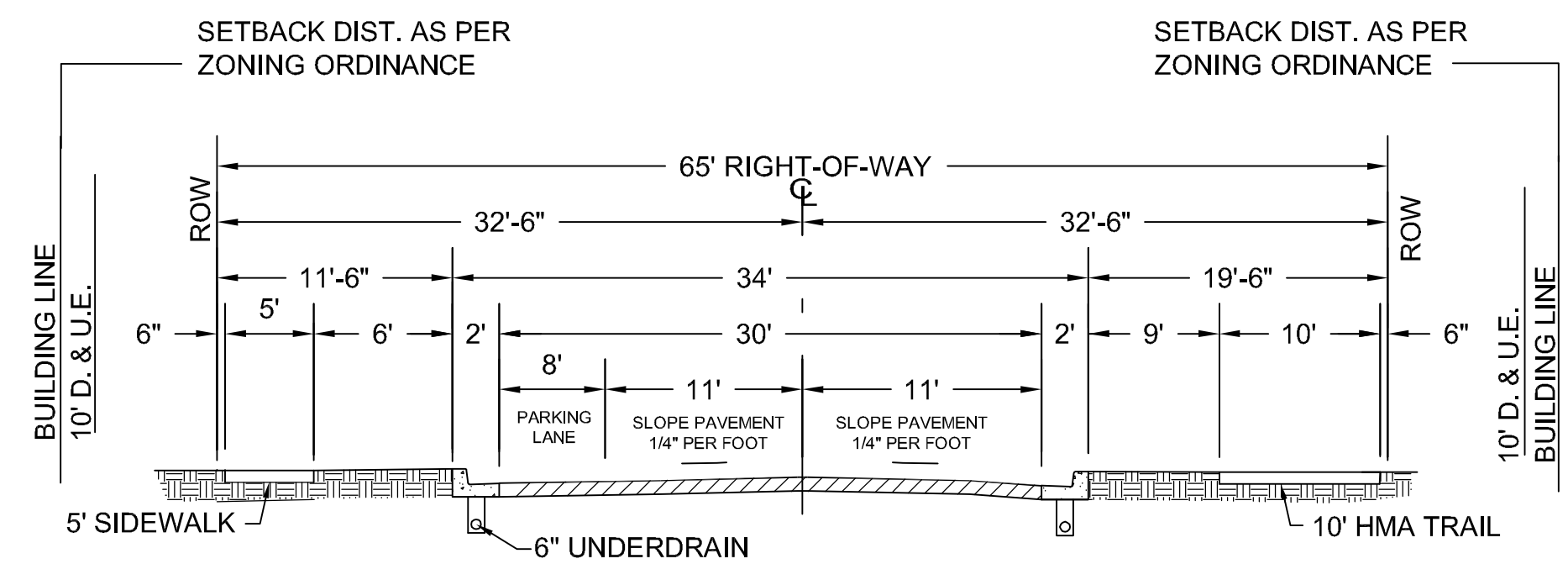

NOTE: TWO 11'-0" MOVING LANES AND ONE 8'-0" PARKING LANE AS SHOWN ABOVE.

**MINOR COLLECTOR STREET**

NOT TO SCALE

NOTE: PEDESTRIAN RAMPS  
AT INTERSECTIONS SHALL MEET A.D.A.  
(AMERICAN DISABILITY ACT) SPECIFICATIONS.

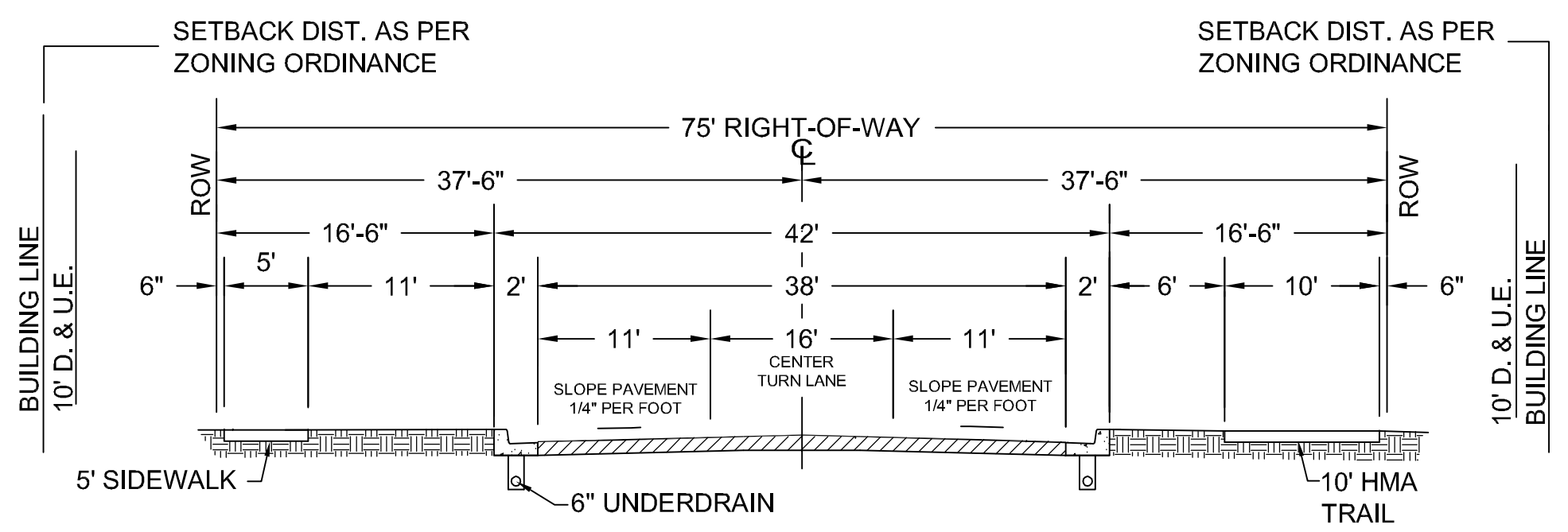

NOTE:  
THREE MOVING LANES WITH NO PARKING LANES AS SHOWN ABOVE.  
TWO OUTSIDE LANES OF 11'-0" EACH, CENTER LANE 16'-0" TOTAL, 12'-0" TURN LANE WITH  
4'-0" DIVING CURB (INTERMITTENT AS NEEDED).  
OPTIONAL: ADD 8'-0" OF PAVEMENT FOR EACH PARKING LANE.

**MAJOR COLLECTOR STREET**

NOT TO SCALE

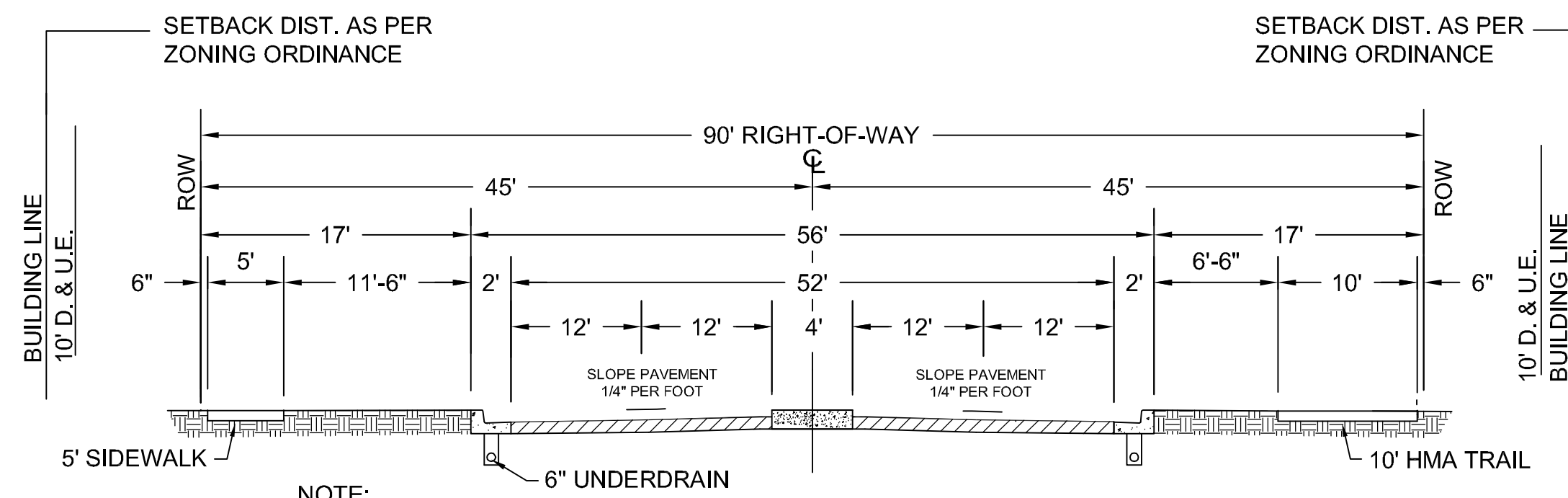

NOTE:  
FOUR 12'-0" MOVING LANES, 4'-0" CENTER CURBS, NO PARKING LANES AS SHOWN ABOVE  
OPTIONAL: ADD 8'-0" OF PAVEMENT FOR EACH PARKING LANE.

**MINOR ARTERIAL STREET**

NOT TO SCALE

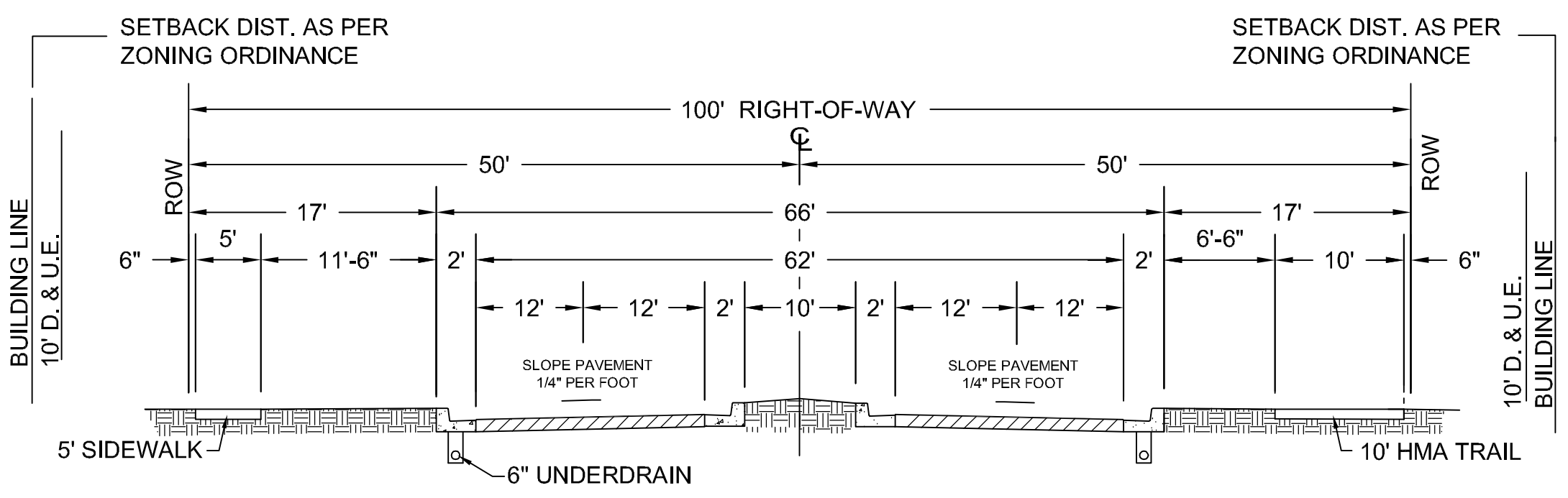

NOTE:  
INSTALL 12'-0" MOVING LANES, 10'-0" GRASS MEDIAN WITH OCCASIONAL CENTER TURN LANES  
AND/OR CROSS-OVERS, NO PARKING LANES AS SHOWN ABOVE.  
BOULEVARD HAS POTENTIAL TO BECOME FIVE-LANE ARTERIAL IF WARRANTED.  
OPTIONAL: ADD 8'-0" OF PAVEMENT FOR EACH PARKING LANE.

**MAJOR ARTERIAL STREET**

NOT TO SCALE

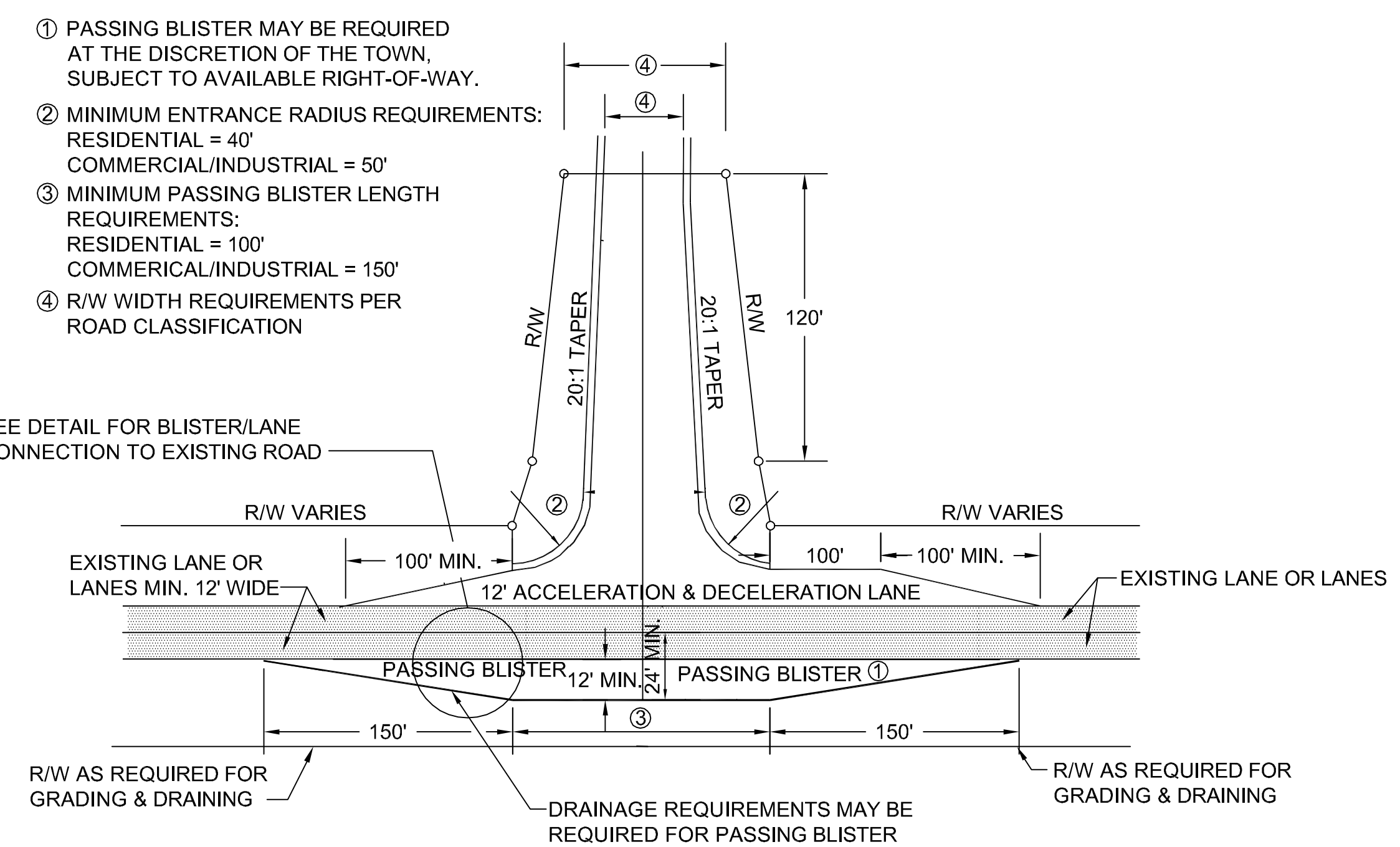

- ① PASSING BLISTER MAY BE REQUIRED AT THE DISCRETION OF THE TOWN, SUBJECT TO AVAILABLE RIGHT-OF-WAY.
- ② MINIMUM ENTRANCE RADIUS REQUIREMENTS:  
RESIDENTIAL = 40'  
COMMERCIAL/INDUSTRIAL = 50'
- ③ MINIMUM PASSING BLISTER LENGTH REQUIREMENTS:  
RESIDENTIAL = 100'  
COMMERCIAL/INDUSTRIAL = 150'
- ④ R/W WIDTH REQUIREMENTS PER ROAD CLASSIFICATION

NOTE:  
THIS DRAWING REPRESENTS THE MINIMUM REQUIREMENTS FOR A PUBLIC ROAD ENTRANCE.  
LARGER AND/OR LONGER ACCELERATION AND DECELERATION LANES MAY BE REQUIRED WHEN  
DEEMED NECESSARY BY THE TOWN OF WHITESTOWN TO ADEQUATELY SERVE THE ANTICIPATED  
TYPES AND VOLUMES OF TRAFFIC. LENGTH OF ACCELERATION AND DECELERATION LANES MAY BE  
MODIFIED WHEN WARRANTED AT THE DISCRETION OF THE PLANNING COMMISSION.

**MINIMUM PUBLIC ROAD TO PUBLIC ROAD  
ENTRANCE REQUIREMENTS**

NOT TO SCALE



PRINTED: 7/30/2015 @ 3:11PM

FILE NAME: L:\AutoCAD Resources\linby\_Sanitary\Client\_Standards\Whitestown - 120409\Details 2015\SHEET\_08\_ROAD-DETS.dwg

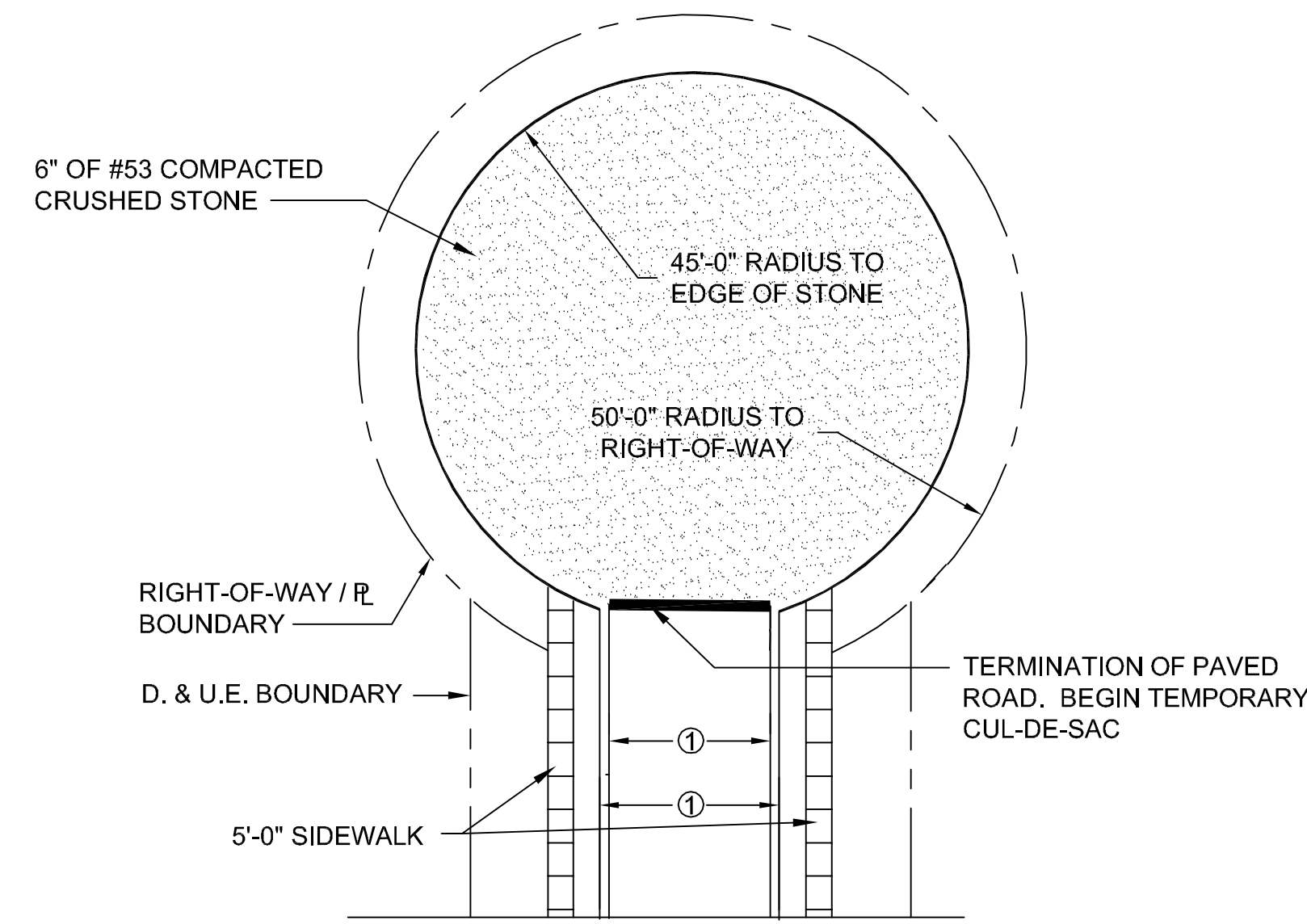

NOTE:  
DESIGN AND CONSTRUCTION OF TEMPORARY CUL-DE-SACS MUST PROVIDE APPROPRIATE DRAINAGE TO PREVENT PONDING.  
① R/W AND ROAD WIDTH REQUIREMENTS PER ROAD CLASSIFICATION

**TEMPORARY CUL-DE-SAC**

NOT TO SCALE

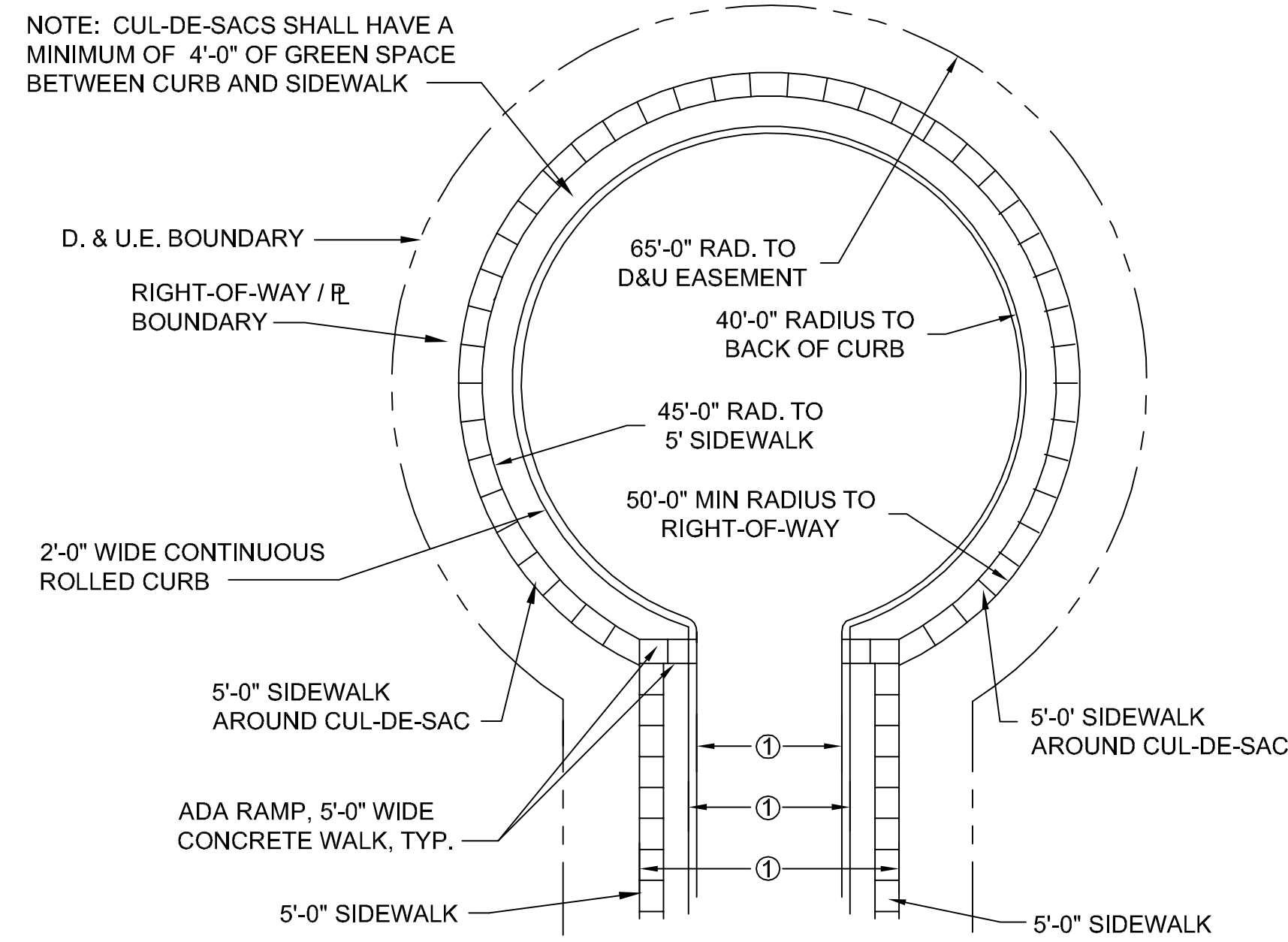

① R/W AND ROAD WIDTH REQUIREMENTS PER ROAD CLASSIFICATION

**RESIDENTIAL CUL-DE-SAC TURNAROUNDS**

NOT TO SCALE

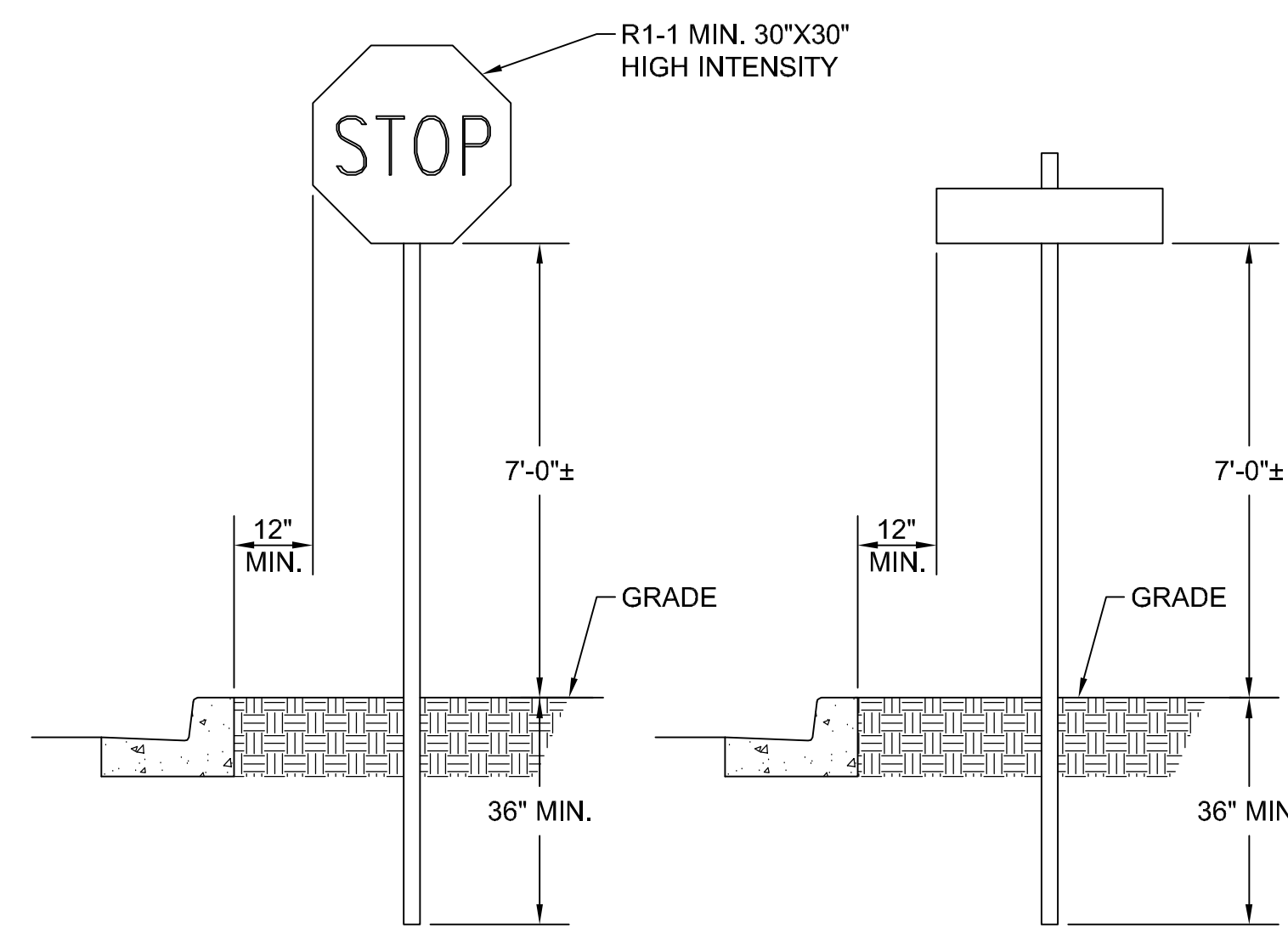

STOP SIGN

STREET NAME SIGN

NOTE: STREET NAME SIGNS TO BE LOCATED AT ALL STREETS.

**STREET SIGNAGE DETAILS**

NOT TO SCALE

**TRAFFIC CONTROL AND SIGNAGE NOTES:**

1. THE CONTRACTOR/DEVELOPER SHALL PROVIDE AND INSTALL ALL STREET NAME AND ROAD SIGNS PER CURRENT INDOT STANDARDS AND TOWN OF WHITESTOWN DETAILS. ALL TRAFFIC CONTROL DEVICES SHALL COMPLY WITH THE CURRENT INDIANA MUTCD.
2. MATERIALS SHALL BE FREE OF BURRS, PITS AND BLEMISHES, AND SHALL PRESENT A SMOOTH CLEAN SURFACE.
3. SIGN BLANKS SHALL MEET INDOT SPECIFICATIONS UNLESS OTHERWISE SPECIFIED.
4. ALL STREET SIGNS SHALL HAVE GREEN BACKGROUND WITH WHITE LETTERS, NUMBERS AND BORDERS ON EXTRUDED ALUMINUM BLADES.
5. THE STREET NAME LETTERS TO BE ENGINEER GRADE: 9" BLADES WITH 6" NUMBERS, 6" CAPITAL LETTERS AND 4.5" LOWER-CASE LETTERS ON ALL STREETS.
6. STOP SIGNS SHALL BE MIN. 30" HIGH INTENSITY.
7. SIGN BOLTS TO BE PER INDOT SPECIFICATIONS. BOLTS SHALL BE THEFT PROOF.
8. SPEED LIMIT SIGNS SHALL BE 24"x30" HIGH INTENSITY OR ENGINEER GRADE.
9. SIGN POST SHALL BE GALVANIZED U-CHANNEL (3LBS/FT), DRIVEN INTO THE GROUND. NO EXCAVATION SHALL BE DONE TO PLACE SIGNS.
10. LARGER SIGNS MAY BE NEEDED FOR ROAD CLASSIFICATIONS GREATER THAN LOCAL PER INDIANA MUTCD REQUIREMENTS.



**TOWN OF WHITESTOWN STREET DESIGN STANDARDS**

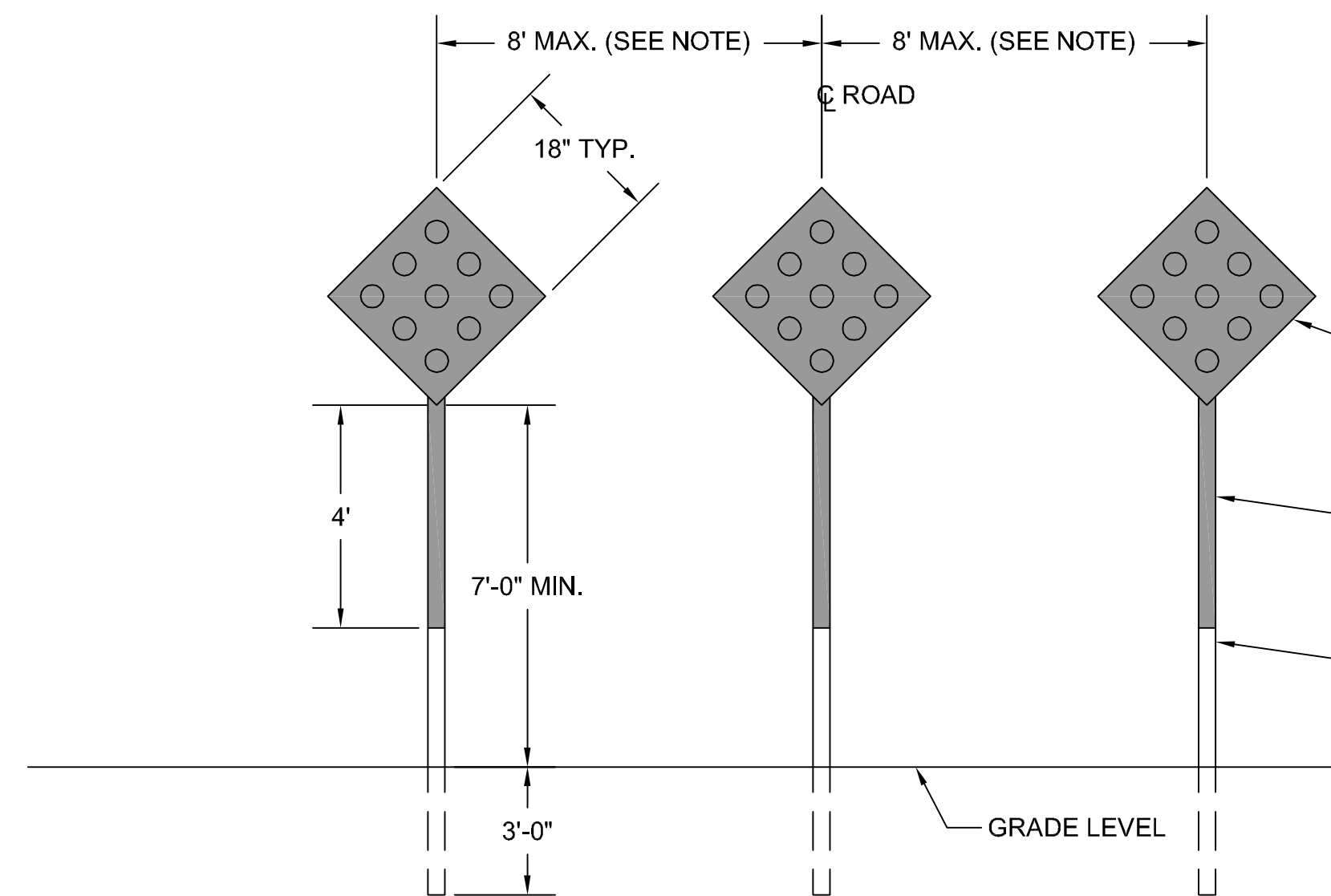

NOTE:  
MORE THAN THREE SIGNS WILL BE REQUIRED ON ROADS WIDER THAN 24 FEET.

INDOT 18"x18" "OM4-1" SIGN WITH HIGH-INTENSITY PRISMATIC RED REFLECTIVE SHEETING ON 0.080" THICK ALUMINUM SIGN BLANK (SEE INDOT STANDARD SIGN DETAILS)  
4"x48" HIGH-INTENSITY PRISMATIC RED REFLECTIVE SHEETING ON 0.080" THICK ALUMINUM SIGN BLANK  
GALVANIZED 10-GAUGE U-CHANNEL POST OR 2 1/2" GALVANIZED SQUARE POST WITH ANCHORS

**END OF ROADWAY DETAIL**

NOT TO SCALE

NOTE:  
END OF ROADWAYS (DEAD-ENDS) MUST HAVE CUL-DE-SAC OR HAMMERHEAD TURN-AROUND SUFFICIENT FOR FIRE TRUCKS.

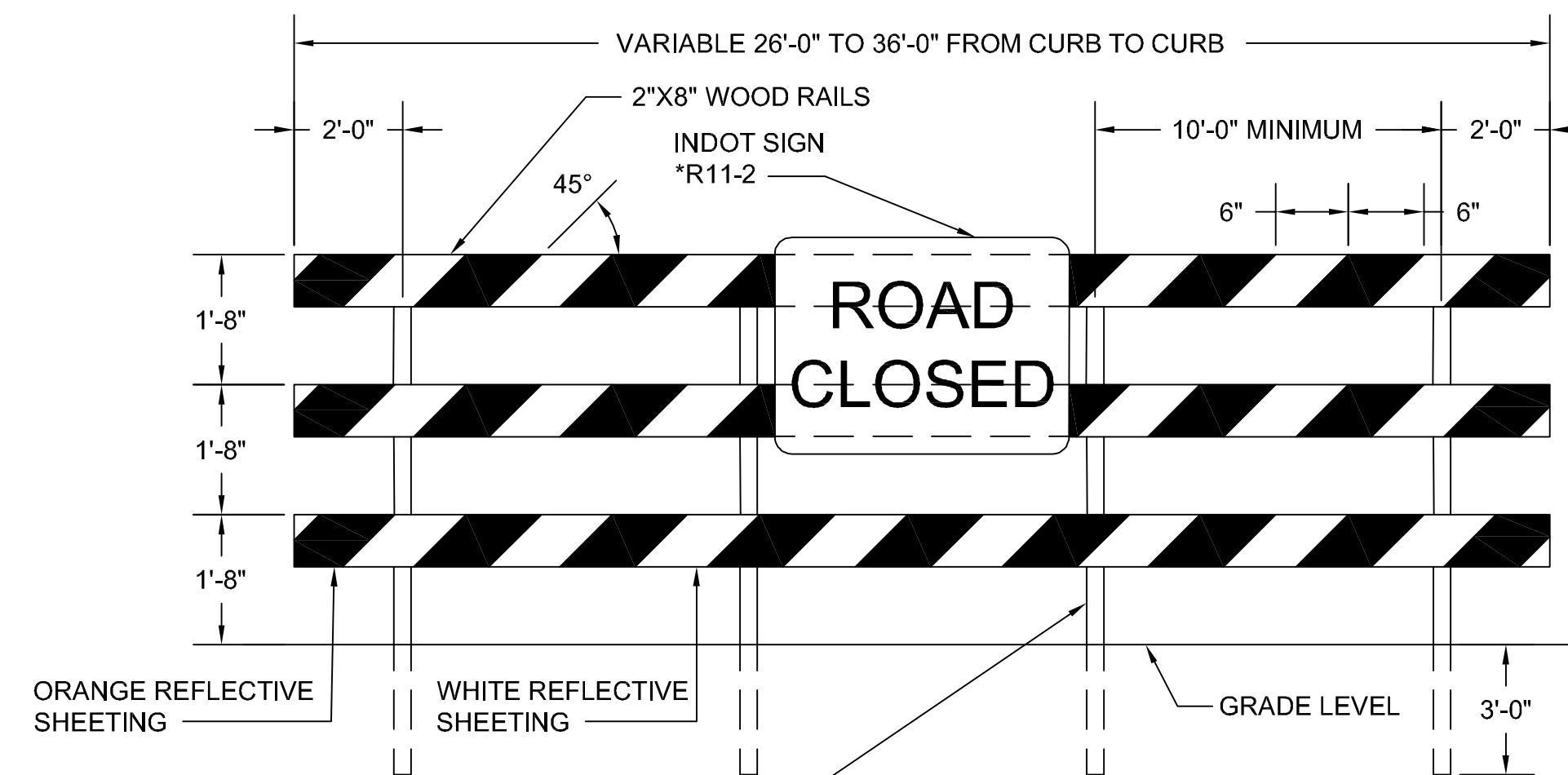

- NOTES:
1. LOCATION OF BARRICADE AS PER PLANS.
  2. \*\* SEE INDOT STANDARD DETOUR SIGNS DETAILS.
  3. REFER TO SECTION 800 OF THE INDIANA DEPARTMENT OF TRANSPORTATION STANDARD SPECIFICATIONS AND LATEST ADDITION OF INDIANA MANUAL OF UNIFORM TRAFFIC CONTROL DEVICES.

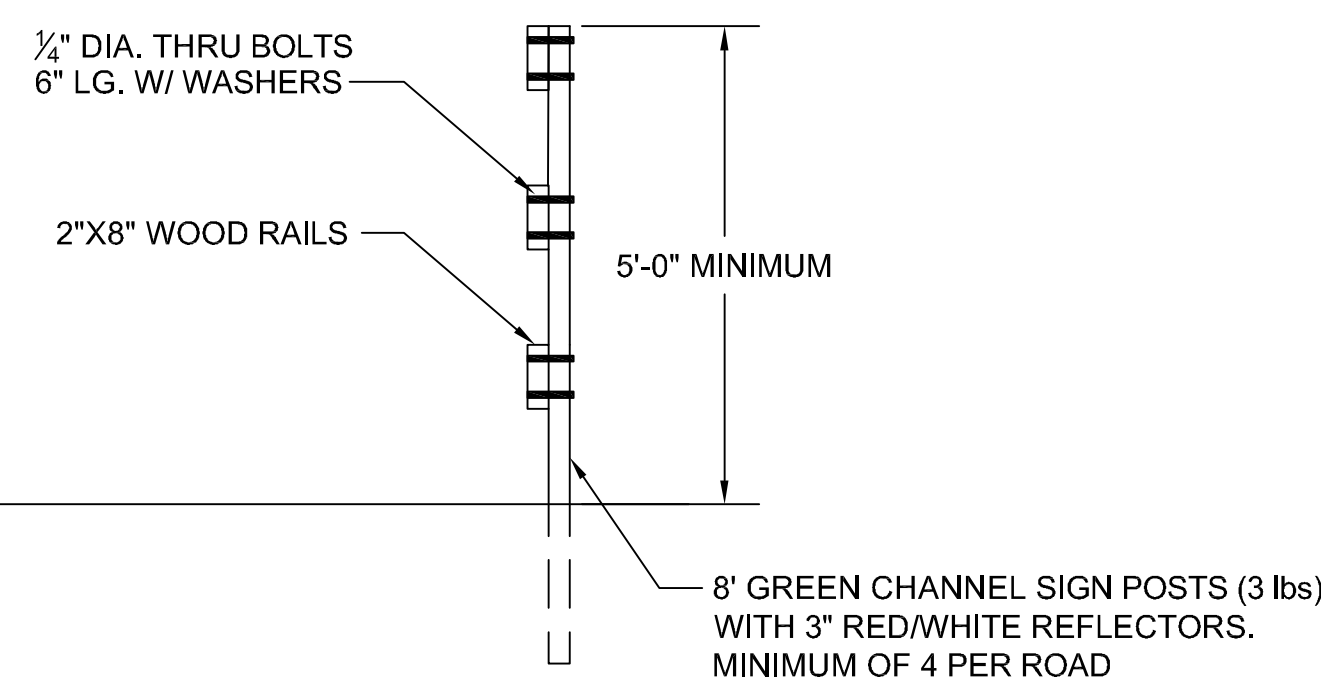

**STANDARD BARRICADE**

NOT TO SCALE

8' GREEN CHANNEL SIGN POSTS (3 lbs) WITH 3" RED/WHITE REFLECTORS. MINIMUM OF 4 PER ROAD

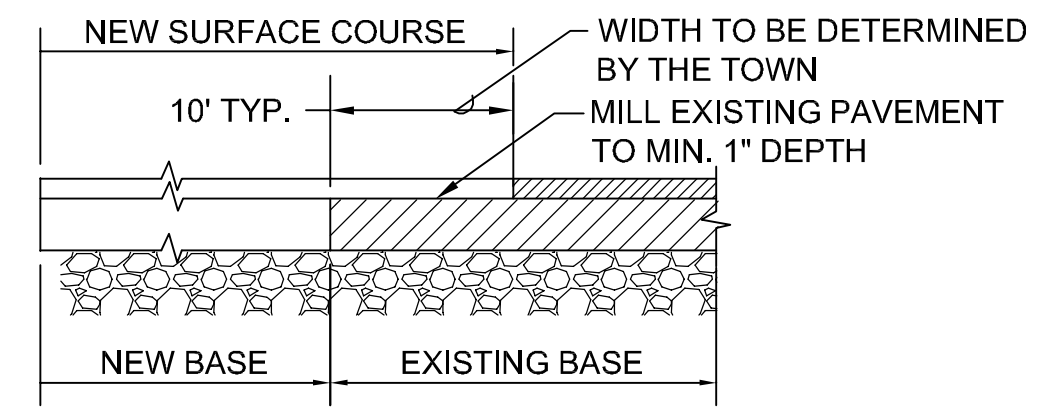

**CONNECTION TO EXISTING STREETS**

NOT TO SCALE

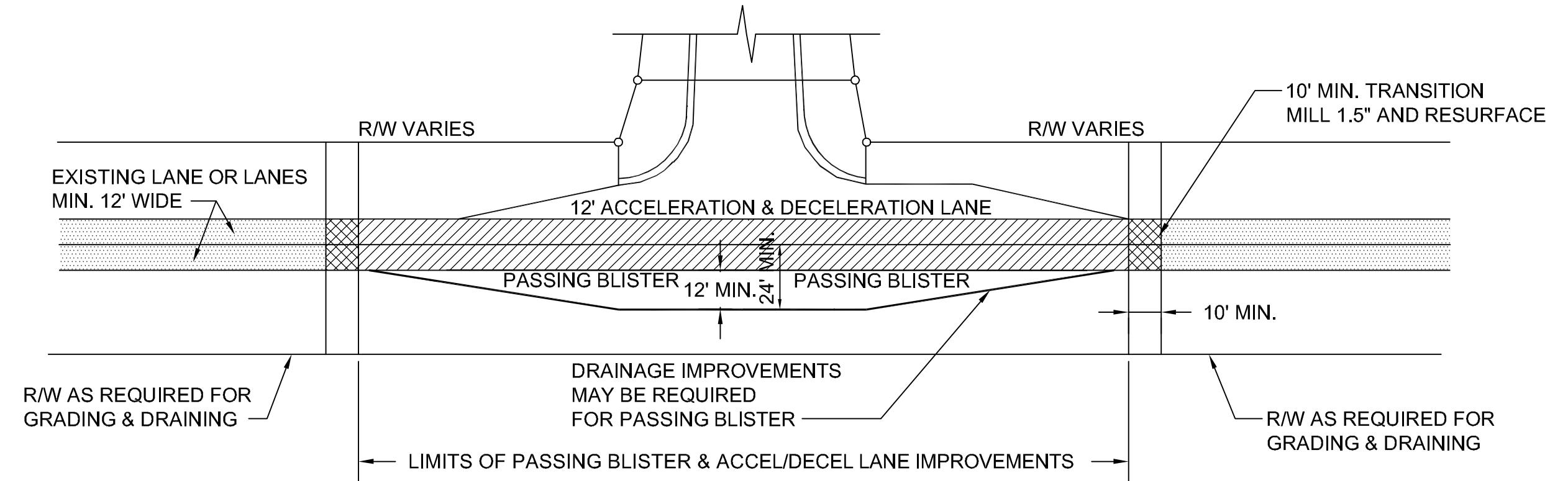

**ROADWAY IMPROVEMENT REQUIREMENTS AT PRIVATE ENTRANCE:**

THE MAIN ROAD SHALL BE RECONSTRUCTED FOR THE ENTIRE LENGTH OF THE PASSING BLISTER AND ACCEL/DECEL LANE IMPROVEMENTS. SAW CUT EXISTING ASPHALT PAVEMENT AT THE LIMITS OF CONSTRUCTION OF THE ACCEL/DECEL LANES AND PASSING BLISTER. ALL EXISTING ASPHALT PAVEMENT SHALL BE REMOVED THROUGH THE LENGTH OF WIDENING. PREPARE SUBGRADE FOR NEW PASSING BLISTER, ACCELERATION & DECELERATION LANES, AND MAIN ROADWAY ACCORDING TO THE REQUIREMENTS OF THE TOWN OF WHITESTOWN STANDARD DETAILS.

ASPHALT PAVING OF THE PASSING BLISTER AND ACCELERATION AND DECELERATION LANES SHALL MEET THE MINIMUM REQUIREMENTS OF THE TOWN OF WHITESTOWN. ASPHALT PAVING OF THE MAIN ROAD LANES SHALL MEET THE MINIMUM REQUIREMENTS OF THE TOWN OF WHITESTOWN FOR ROADWAY PAVING, OR MATCH THE DEPTH OF EXISTING ASPHALT, WHICHEVER IS GREATER.

MILL EXISTING ROAD 1.5" DEEP A MINIMUM OF 10' BEYOND THE ROADWAY REPLACEMENT LIMITS AT EACH END. CONTINUE 1.5" HMA SURFACE PAVING OVER THE MILLED AREA TO PROVIDE A SMOOTH TRANSITION BETWEEN NEW AND EXISTING ASPHALT PAVEMENT. CURBING SHALL BE EXTENDED THE ENTIRE LENGTH OF THE ACCELERATION AND DECELERATION LANES. IMPROVEMENTS SHALL BE MADE AS NECESSARY TO PROVIDE APPROPRIATE DRAINAGE WHERE THE PASSING BLISTER IS CONSTRUCTED. ADDITIONAL RIGHT OF WAY SHALL BE ACQUIRED AS NECESSARY TO CONSTRUCT PROPER DRAINAGE IMPROVEMENTS AT PASSING BLISTER.

REQUIRED ON ALL ARTERIAL AND COLLECTOR STREETS AT THE TOWN'S DISCRETION.

**ROADWAY IMPROVEMENTS AT NEW DEVELOPMENT ENTRANCES**

NOT TO SCALE

NO.	DATE	DESCRIPTION

SCALE: N.T.S.

SHEET NO. 8

PRINTED: 7/30/2015 @ 3:13PM

FILE NAME: L:\AutoCAD Resources\Info Sanitary\Client Standards\Whitestown - 120409\Details 2015\SHEET\_06\_ROAD DETS.dwg

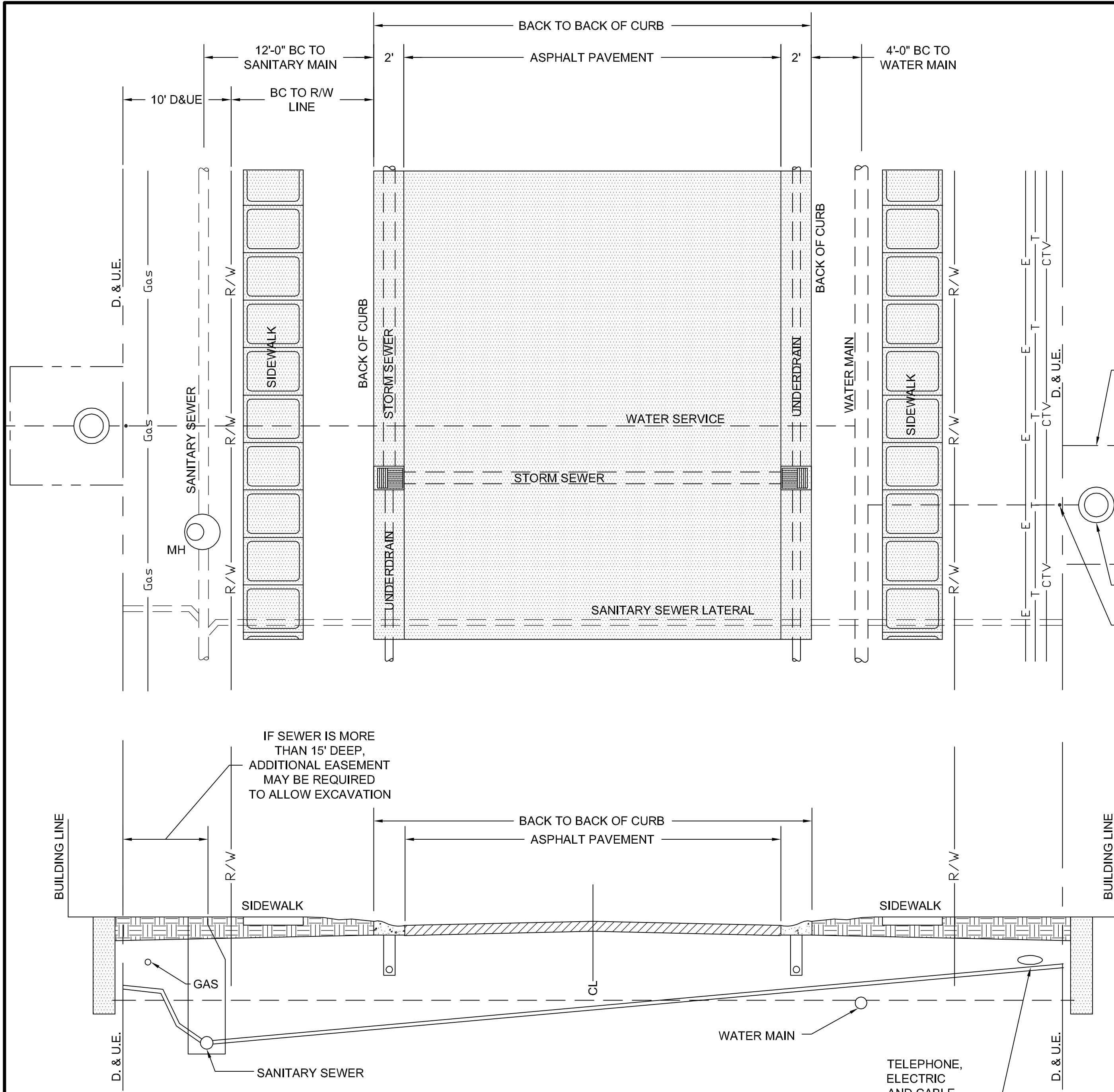

**GENERAL UTILITY LOCATION PLAN AND SECTION**

NOT TO SCALE

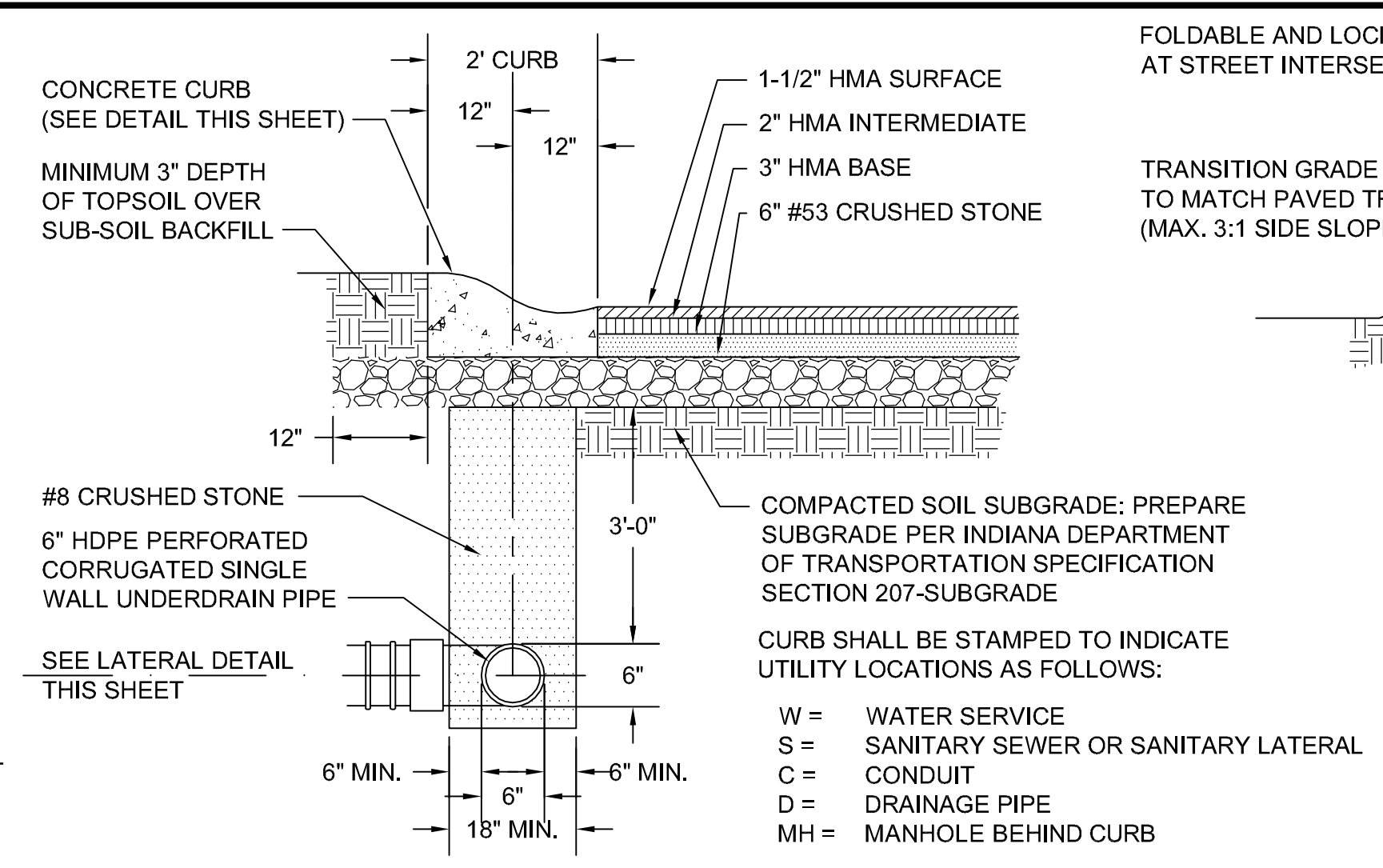

**LOCAL STREET MINIMUM PAVEMENT AND UNDERDRAIN DETAIL: RESIDENTIAL DEVELOPMENTS**

NOT TO SCALE

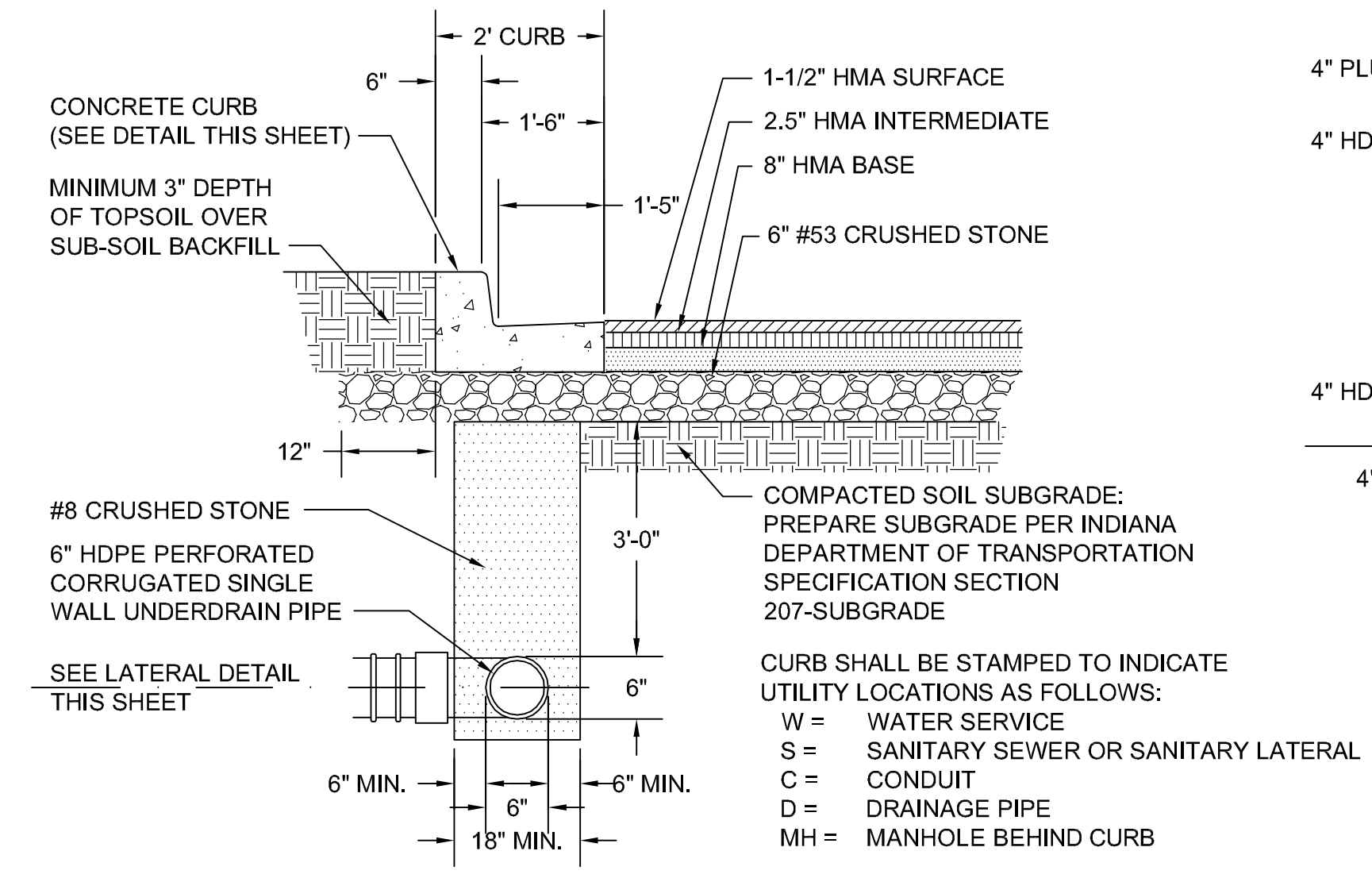

**LOCAL STREET MINIMUM PAVEMENT AND UNDERDRAIN DETAIL: COMMERCIAL AND INDUSTRIAL DEVELOPMENTS**

NOT TO SCALE

**NOTES:**

1. DEVELOPER'S ENGINEER SHALL VERIFY PAVEMENT DESIGN BASED ON SOILS INVESTIGATION IN THE AREA OF CONSTRUCTION.
2. FOR STREETS WITH HIGHER CLASSIFICATIONS THAN LOCAL, DEVELOPER'S ENGINEER SHALL SUBMIT PROPOSED PAVEMENT DESIGN FOR TOWNS APPROVAL.
3. COMMERCIAL DRIVE ENTRANCES SHALL BE DESIGNED PER APPROPRIATE INDOT REQUIREMENTS.

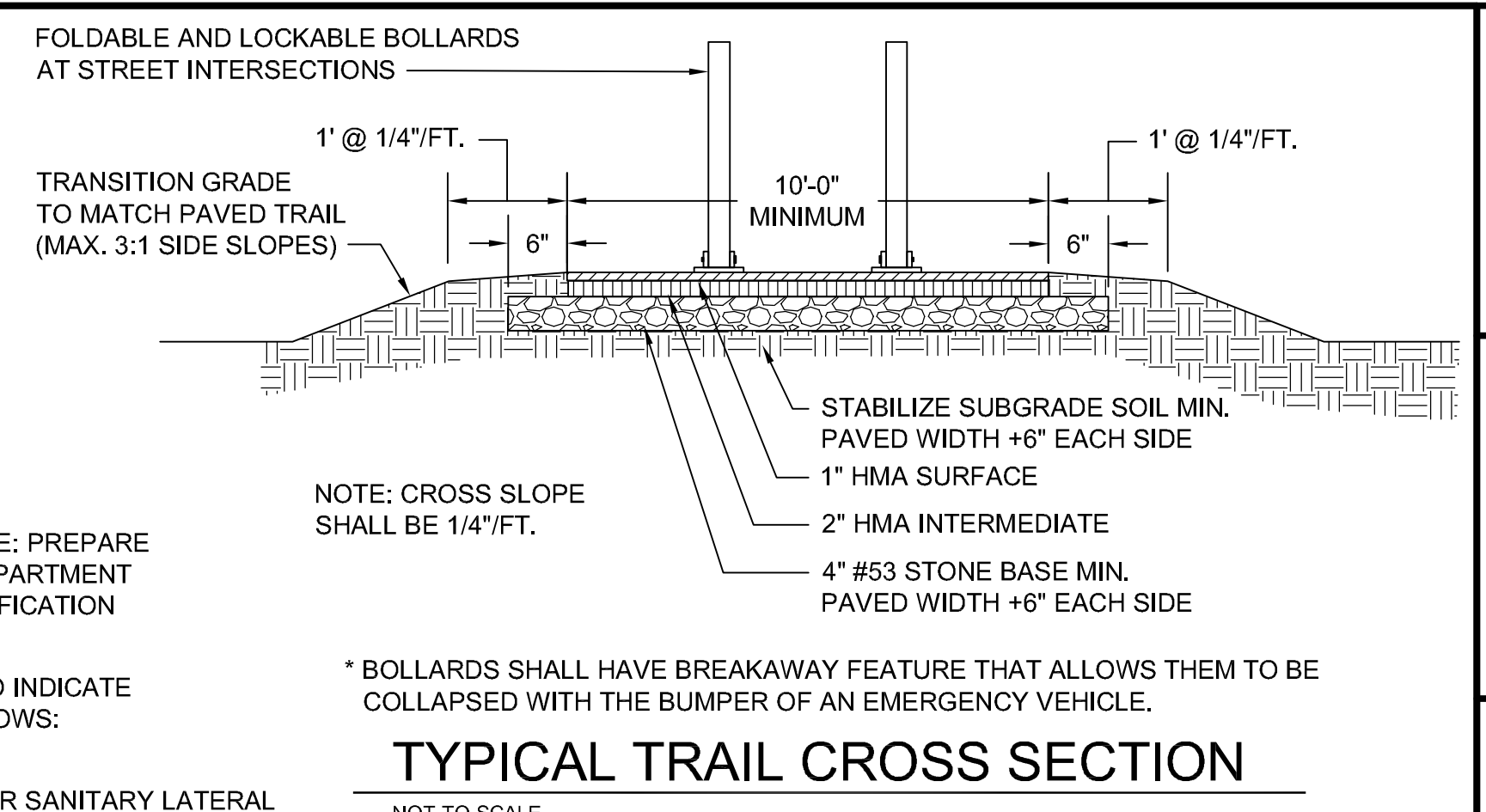

**TYPICAL TRAIL CROSS SECTION**

NOT TO SCALE

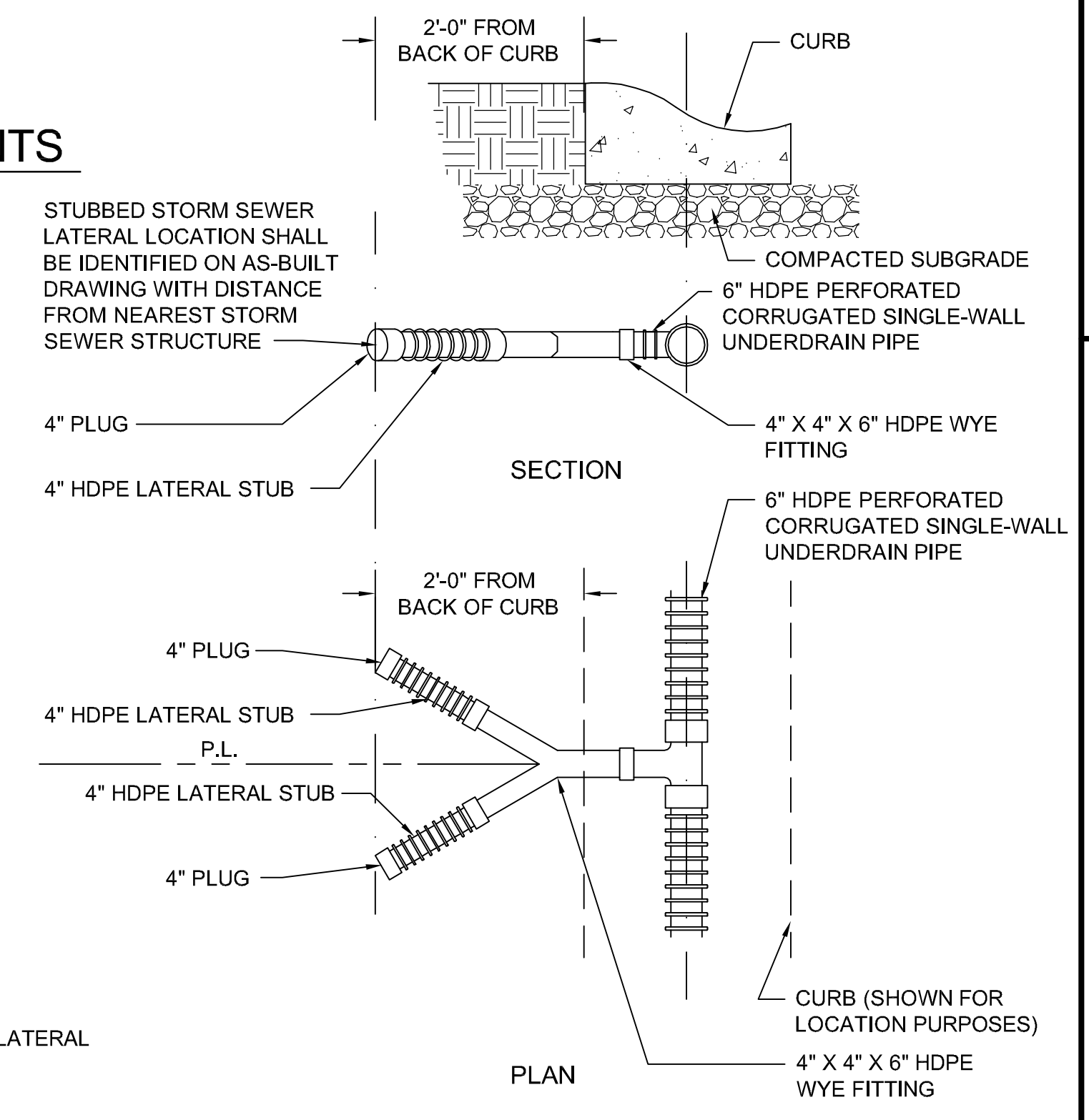

**STORM SEWER LATERAL CONNECTION AT ROAD UNDERDRAIN**

NOT TO SCALE

NOTE: ONLY ALLOWED WHERE REAR YARD DRAIN CONNECTION IS NOT POSSIBLE

**STORM SEWER LATERAL REQUIREMENTS:**

1. ROUTE ALL PROPERTY LATERALS TO REAR YARD STORM SEWERS WHEN POSSIBLE.
2. ALL SUMP PUMP DISCHARGE PIPES SHALL BE CONNECTED TO STORM SEWER SYSTEM. "DAY-LIGHTING" OF SUMP PUMP DISCHARGE PIPES ALLOWED WITH TOWN PERMISSION.
3. SUMP PUMP DISCHARGE PIPE MUST BE CONNECTED TO LATERAL WITH AN APPROPRIATE FITTING.

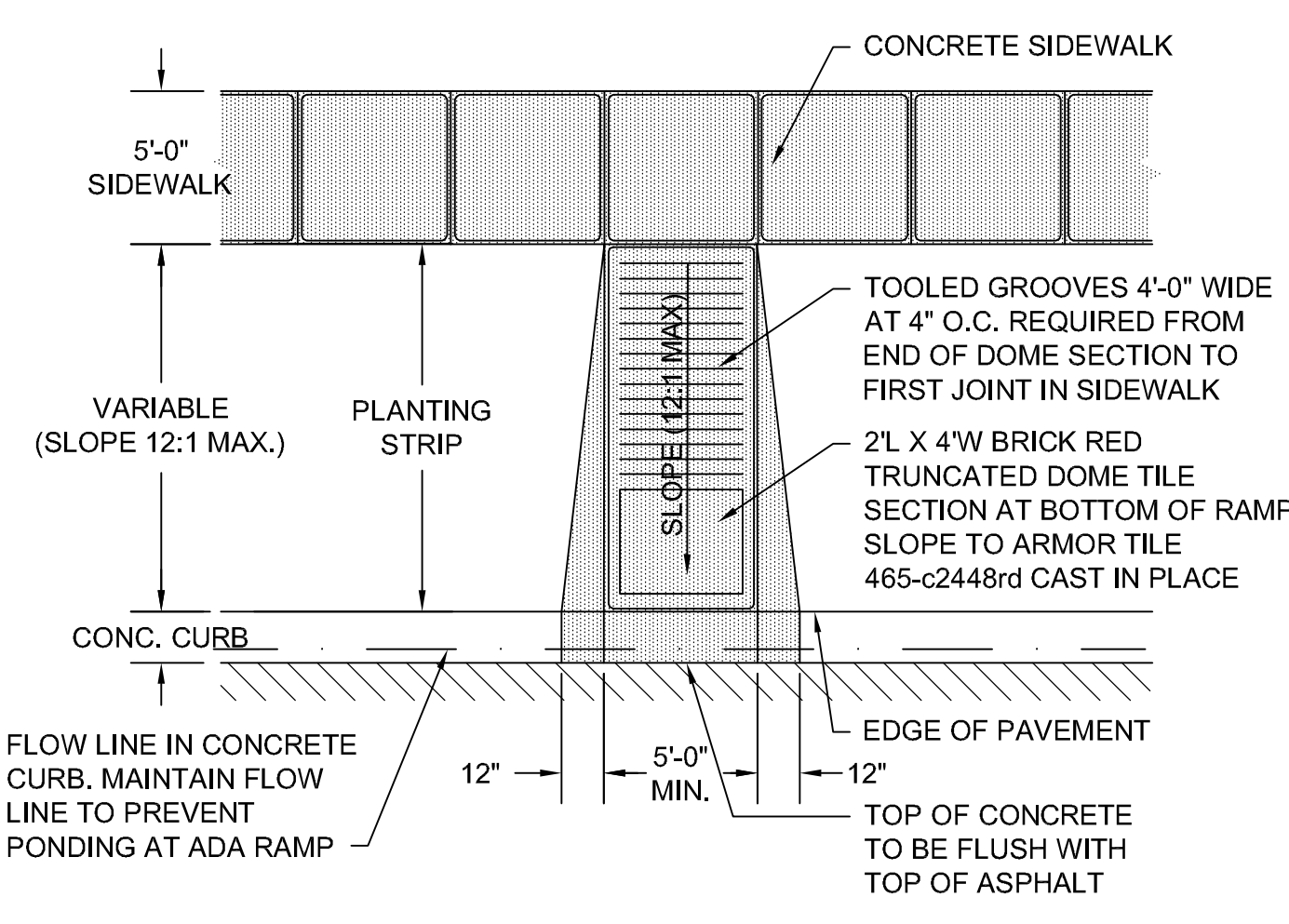

**SIDEWALK ADA RAMP DETAIL**

NOT TO SCALE

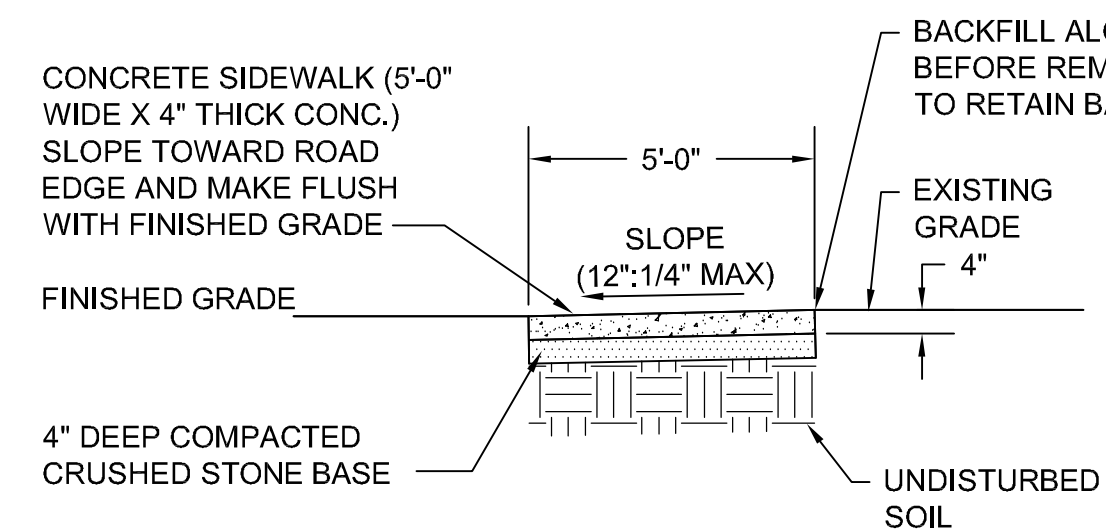

**SIDEWALK SECTION A-A**

NOT TO SCALE

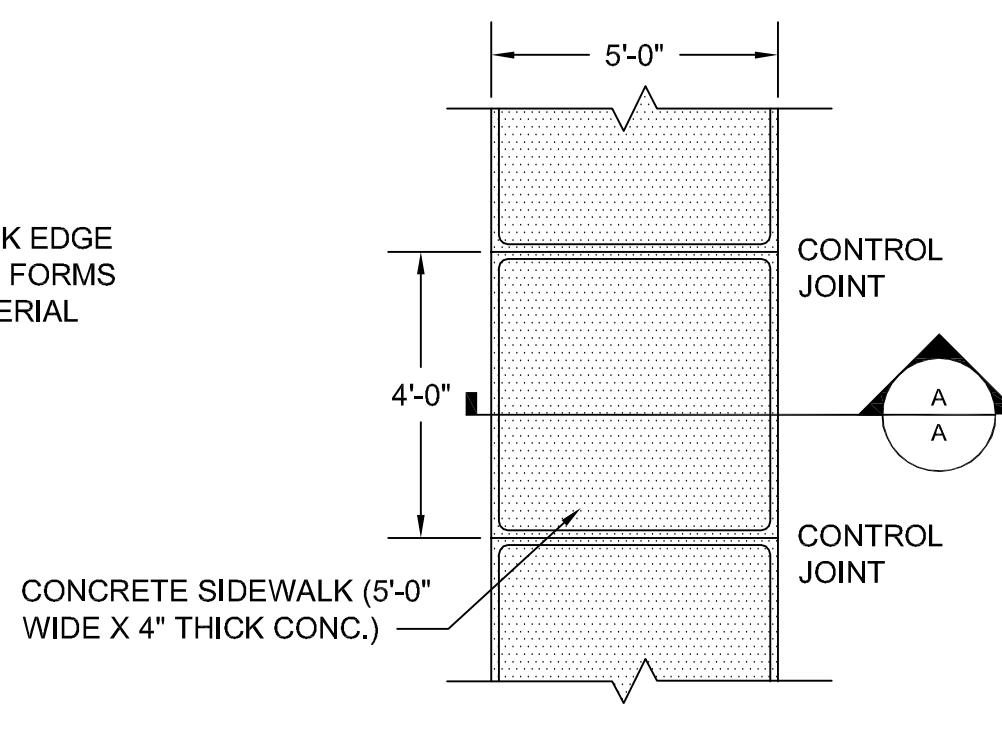

**TYPICAL SIDEWALK DETAIL**

NOT TO SCALE

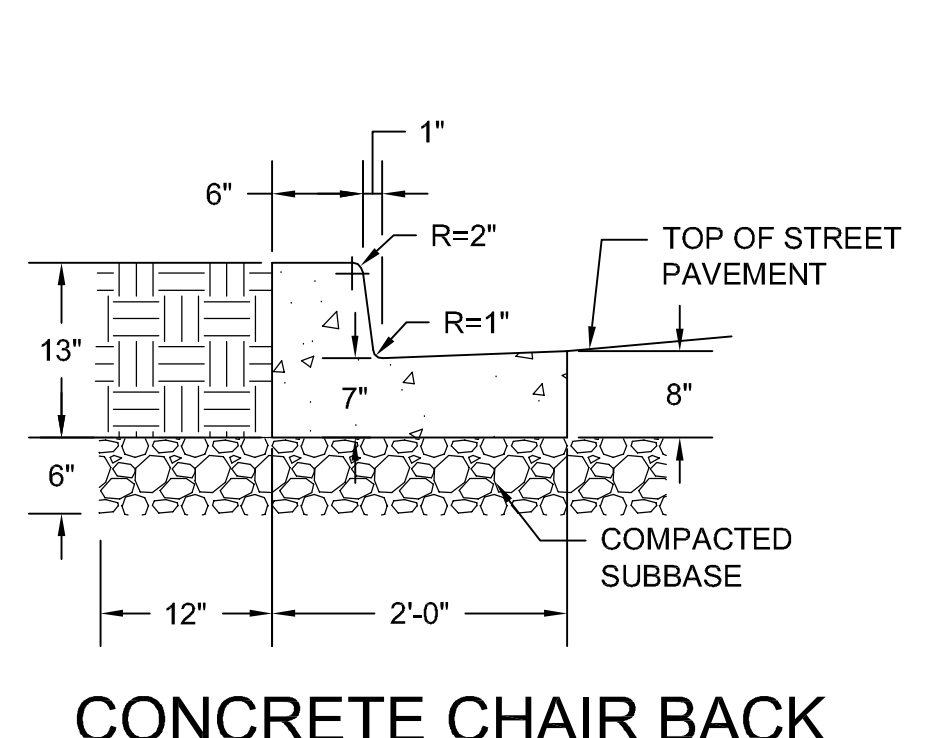

**CONCRETE CHAIR BACK CURB AND GUTTER DETAIL**

NOT TO SCALE

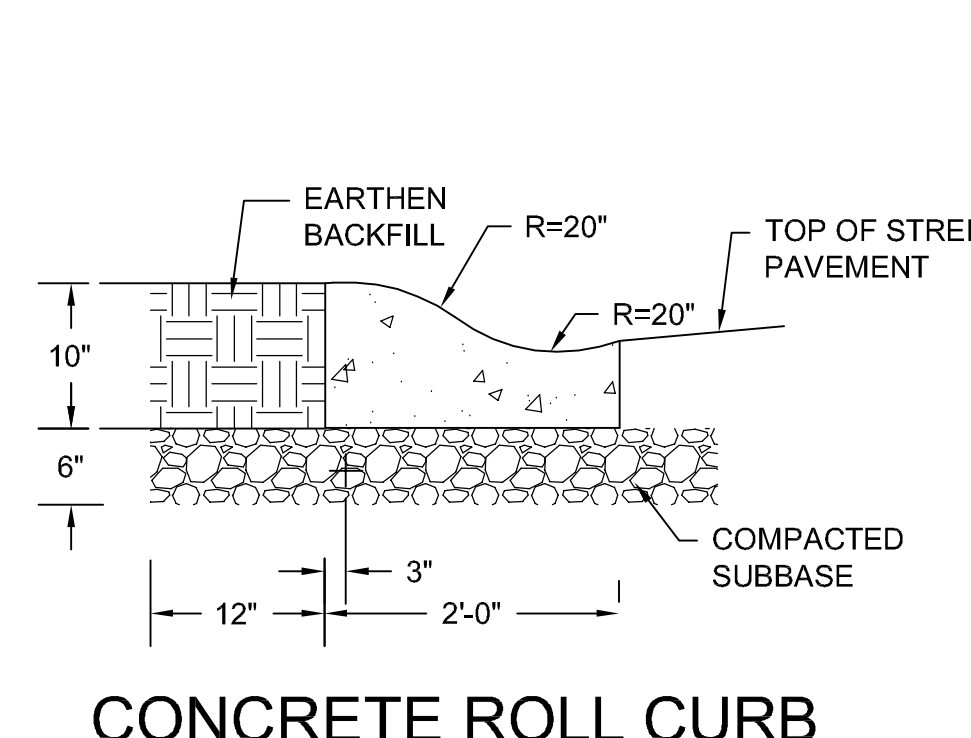

**CONCRETE ROLL CURB AND GUTTER DETAIL**

NOT TO SCALE

NO.	DATE	BY	DESCRIPTION

SCALE: N.T.S.

SHEET NO.



TOWN OF WHITESTOWN  
LIFT STATION LAYOUT AND  
ELECTRICAL DIAGRAM

NO.	DATE	DESCRIPTION

SCALE: NOTED  
SHEET NO.

LIFT STATION DESIGN DATA			
DESCRIPTION	LIFT STATION ID NO. LS1	DESCRIPTION	LIFT STATION ID NO. LS1
	INITIAL DESIGN		INITIAL DESIGN
NUMBER OF DWELLINGS		PLUG VALVE SIZE (IN.)	
GALLONS PER DAY PER RESIDENCE		VALVE VAULT DIMENSIONS	
TOTAL AVERAGE DAILY FLOW (GPD)		VALVE VAULT ACCESS HATCH SIZE	
TOTAL AVERAGE FLOW (GPM)		WETWELL INSIDE DIAMETER (FT.)	
PEAK FLOW RATE (GPM)		WETWELL DEPTH (FT.)	
PUMP FLOW RATE (GPM) * FUTURE		WETWELL ACCESS HATCH SIZE	
FORCE MAIN DIAMETER (IN.)		VISUAL LIGHT & AUDIBLE ALARM	
FORCE MAIN LENGTH (FT.)		EMERGENCY GENERATOR MALE END CONNECTION	
FORCE MAIN VELOCITY (FT./SEC.)		BUILT-IN EMERGENCY GENERATOR TRANSFER SWITCH	
C' VALUE		TOP OF LIFT STATION ELEVATION	
FORCE MAIN HEAD LOSS (FT.)		NORTH INVERT ELEVATION	
FORCE MAIN LIFT (FT.)		SOUTH INVERT ELEVATION	
PUMP WEAR ALLOWANCE (FT.)		EAST INVERT ELEVATION	
FITTING MINOR LOSSES (FT.)		WEST INVERT ELEVATION	
TOTAL DYNAMIC HEAD (FT.)		BOTTOM OF LIFT STATION ELEVATION	
MANUFACTURER & MODEL NUMBER		HIGH LEVEL ALARM ELEVATION	
PUMP HORSEPOWER		LAG PUMP ON ELEVATION	
PUMP SPEED (RPM)		LEAD PUMP ON ELEVATION	
IMPELLER DIAMETER (IN.)		BOTH PUMPS OFF ELEVATION	
POWER SUPPLY		VOL. BETWEEN OFF & LEAD PUMP ON (GAL.)	
NEMA STARTER SIZE		DETENTION TIME @ TOTAL AVERAGE FLOW (MIN.)	
CHECK VALVE SIZE (IN.)			

NOTE:  
DEVELOPER SHALL COMPLETE AND SUBMIT ABOVE TABLE TO TOWN OF WHITESTOWN WHEN PLANNING A LIFT STATION.

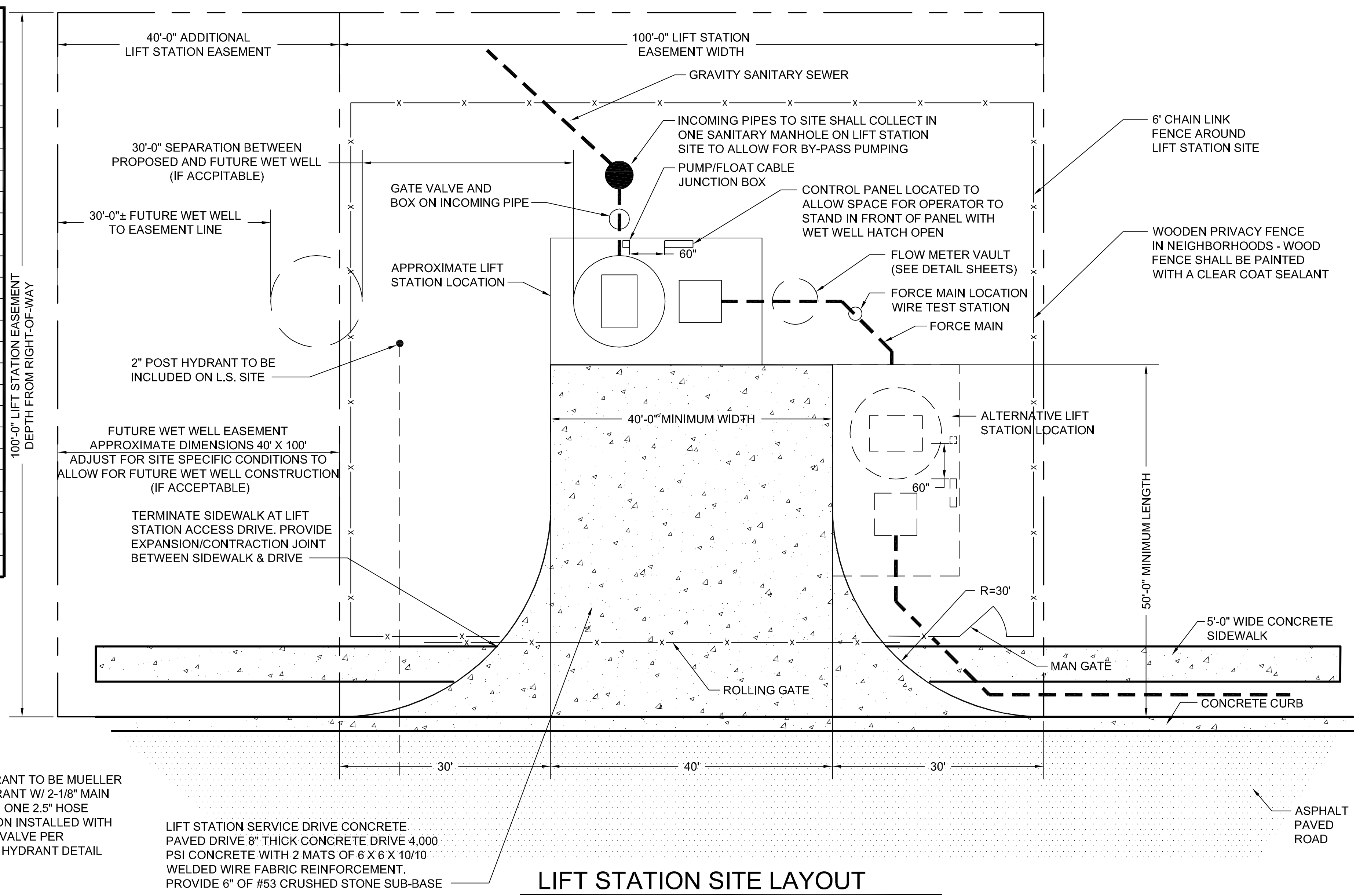

NOTE:  
POST HYDRANT TO BE MUELLER POST HYDRANT W/ 2-1/8" MAIN VALVE AND ONE 2.5" HOSE CONNECTION INSTALLED WITH ISOLATION VALVE PER STANDARD HYDRANT DETAIL

LIFT STATION SERVICE DRIVE CONCRETE PAVED DRIVE 8" THICK CONCRETE DRIVE 4,000 PSI CONCRETE WITH 2 MATS OF 6 X 6 X 10/10 WELDED WIRE FABRIC REINFORCEMENT. PROVIDE 6" OF #53 CRUSHED STONE SUB-BASE

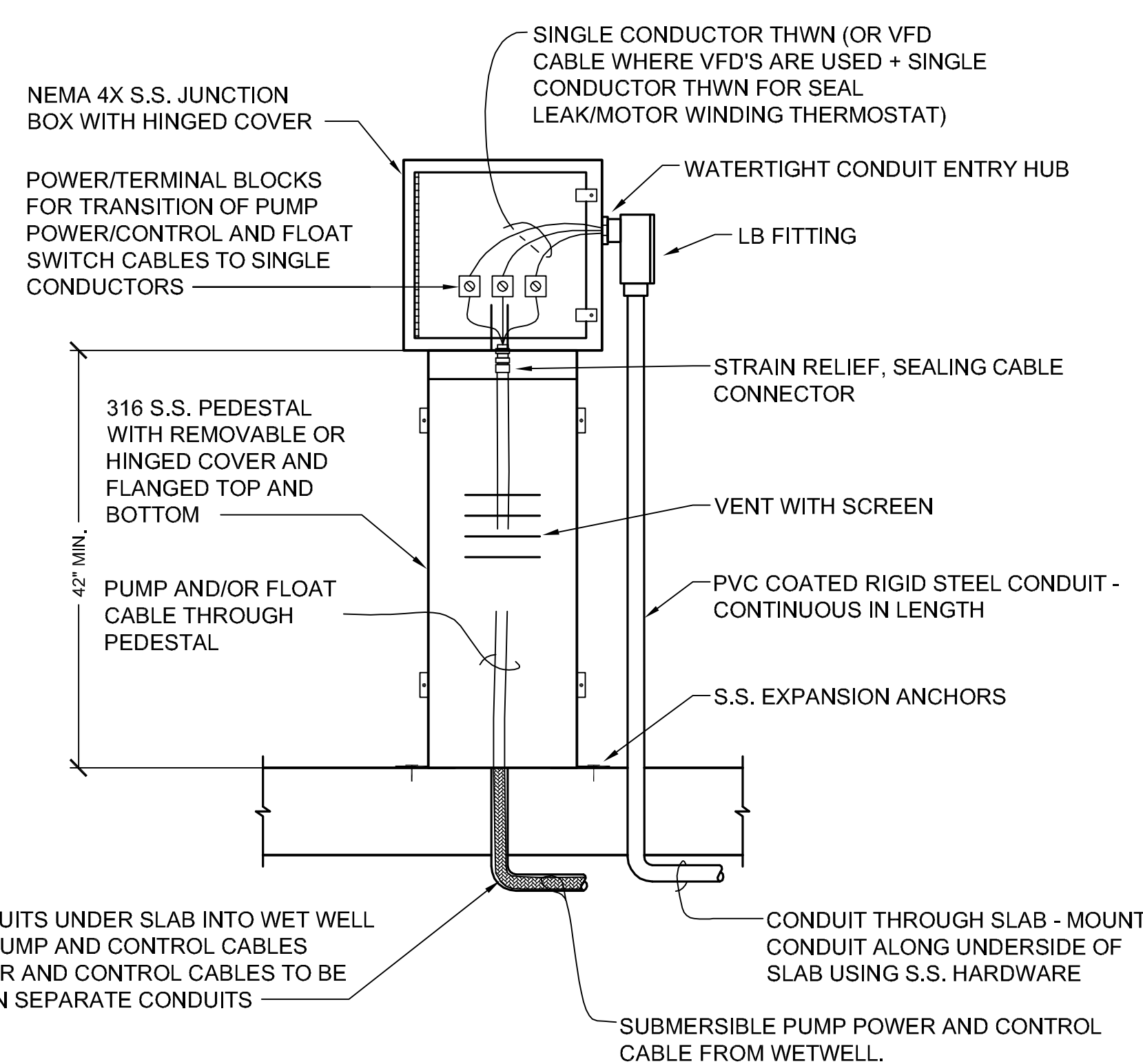

- NOTES:
- JUNCTION BOX SHALL BE SIZED AS REQUIRED TO ACCOMMODATE POWER/TERMINAL BLOCKS AND NUMBER OF CABLES.
  - PROVIDE ADEQUATE POWER AND TERMINAL BLOCKS FOR TRANSITION OF PUMP POWER/CONTROL OR FLOAT CABLES TO SINGLE CONDUCTORS.
  - CONVERT MULTITRODE FACTORY CABLE TO 24 STRAND/12 CONDUCTOR CABLE (GARLAND PART NO. TEM134802008) AT JUNCTION BOX AND EXTEND 12 CONDUCTOR CABLE IN 1" C TO PUMP CONTROL PANEL.
  - PROVIDE STRAIN RELIEF CABLE GRIP AND SEALING CABLE CONNECTORS FOR ALL CABLES ENTERING WETWELL.
  - SEALING CONNECTORS SHALL BE RATED FOR CLASS I, DIVISION 2, GROUP D HAZARDOUS LOCATIONS AND SHALL BE HAWKE 710, OR EQUAL.
  - GROUND LUG IS NOT SHOWN, BUT IS REQUIRED.
  - CONTRACTOR SHALL PROVIDE CONDUIT UNDER SLAB TO ALLOW ROUTING OF PUMP POWER/CONTROL CABLES, TRANSDUCER CABLE AND CAPACITANCE PROBE FROM WETWELL TO JUNCTION BOX.
  - CONTRACTOR SHALL FURNISH AND INSTALL SEALING CONNECTORS FOR PUMP POWER/CONTROL CABLE, TRANSDUCER CABLE AND LEVEL SENSING PROBE CABLE.
  - MANUFACTURER SUPPLIED CABLE FROM PRESSURE TRANSDUCER TO JUNCTION BOX.

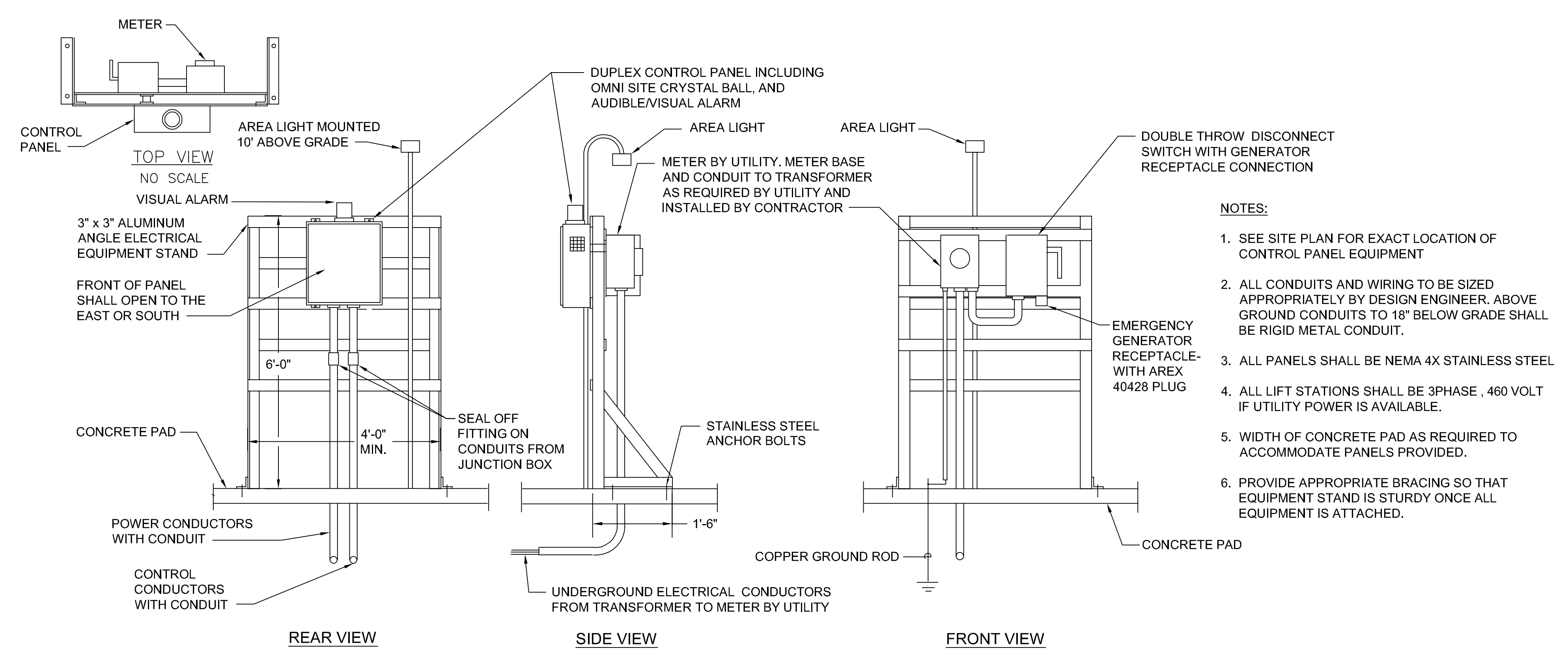

- NOTES:
- SEE SITE PLAN FOR EXACT LOCATION OF CONTROL PANEL EQUIPMENT
  - ALL CONDUITS AND WIRING TO BE SIZED APPROPRIATELY BY DESIGN ENGINEER. ABOVE GROUND CONDUITS TO 18" BELOW GRADE SHALL BE RIGID METAL CONDUIT.
  - ALL PANELS SHALL BE NEMA 4X STAINLESS STEEL
  - ALL LIFT STATIONS SHALL BE 3PHASE, 460 VOLT IF UTILITY POWER IS AVAILABLE.
  - WIDTH OF CONCRETE PAD AS REQUIRED TO ACCOMMODATE PANELS PROVIDED.
  - PROVIDE APPROPRIATE BRACING SO THAT EQUIPMENT STAND IS STURDY ONCE ALL EQUIPMENT IS ATTACHED.

PRINTED: 7/30/2015 @ 3:20PM

FILE NAME: L:\AutoCAD Resources\Inch Sanitary\Client\Standards\Whitestown - 120409\Details 2015\SHEET\_10-L.S-SITE.dwg

NO.	DATE	DESCRIPTION

FORCE MAIN LOCATION WIRE SHALL BE TERMINATED AT A FORCE MAIN MARKER POST INSTALLED ADJACENT TO THE VALVE VAULT. THE POST MARKER SHALL PROVIDE A TERMINAL CONNECTION POINT FOR FORCE MAIN LOCATION WIRE CONNECTION. FORCE MAIN MARKERS WITH TERMINAL CONNECTIONS TO LOCATION WIRE SHALL BE INSTALLED ALONG FORCE MAIN ROUTE WITH MAXIMUM 400 L.F. SPACING. LOCATION WIRE SHALL BE CONTINUOUS BETWEEN LOCATION MARKERS (NO SPLICING). COORDINATE MARKER LOCATIONS WITH THE TOWN OF WHITESTOWN. STATION SHALL BE EQUIVALENT TO HANDLEY INDUSTRIES MODEL PMP 7CE WITH LID C2. THE FOLLOWING INFORMATION SHALL BE CLEARLY PRINTED ON FORCE MAIN MARKER POST: "TOWN OF WHITESTOWN", "SANITARY SEWER LINE BURIED BELOW", "EMERGENCY CONTACT 317-733-8584" AND "CAUTION SEWER PIPELINE". CONTRACTOR SHALL LOCATE ALL PIPE IN PRESENCE OF TOWN OF WHITESTOWN REPRESENTATIVE FOLLOWING COMPLETION OF CONSTRUCTION.

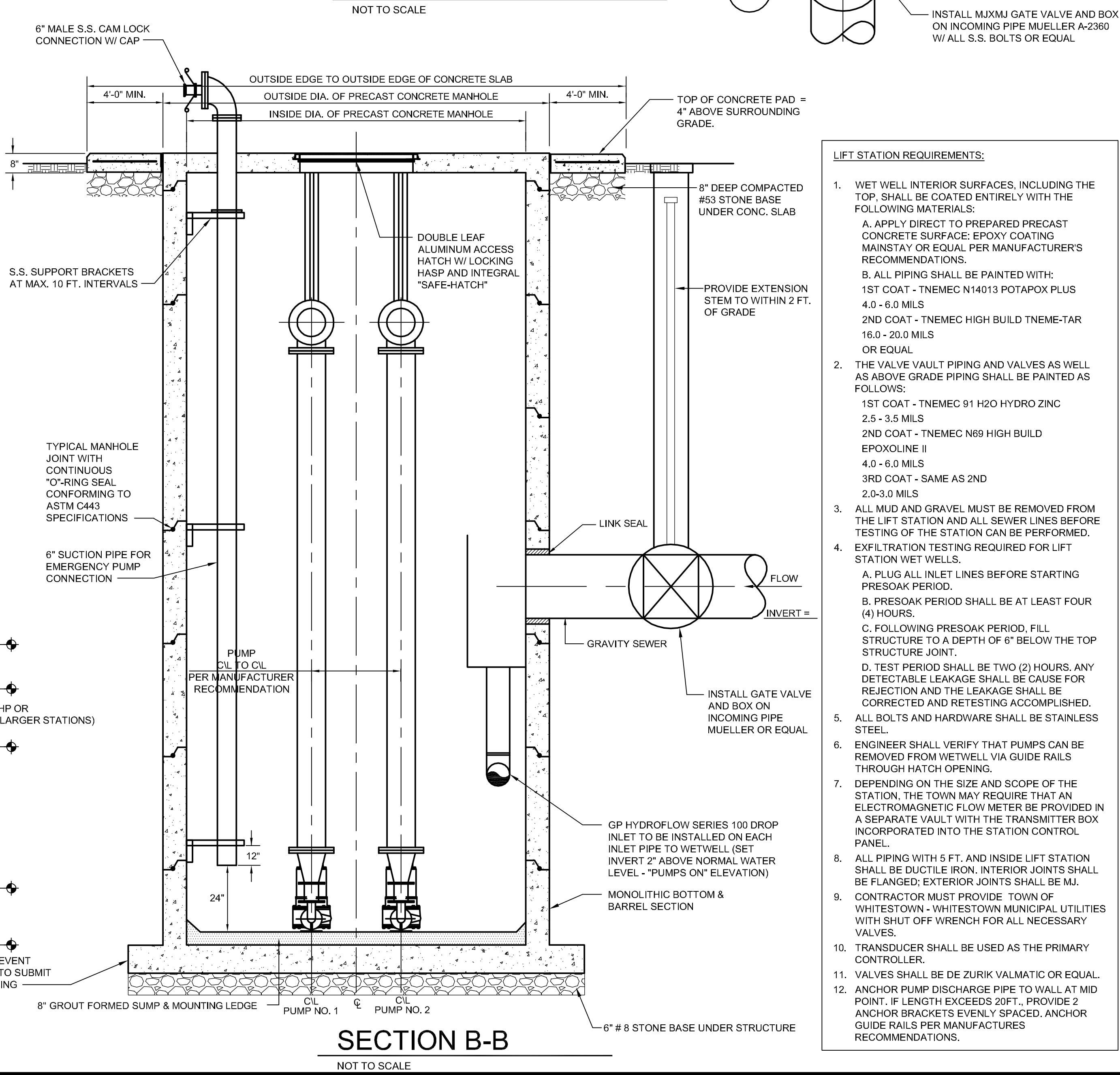
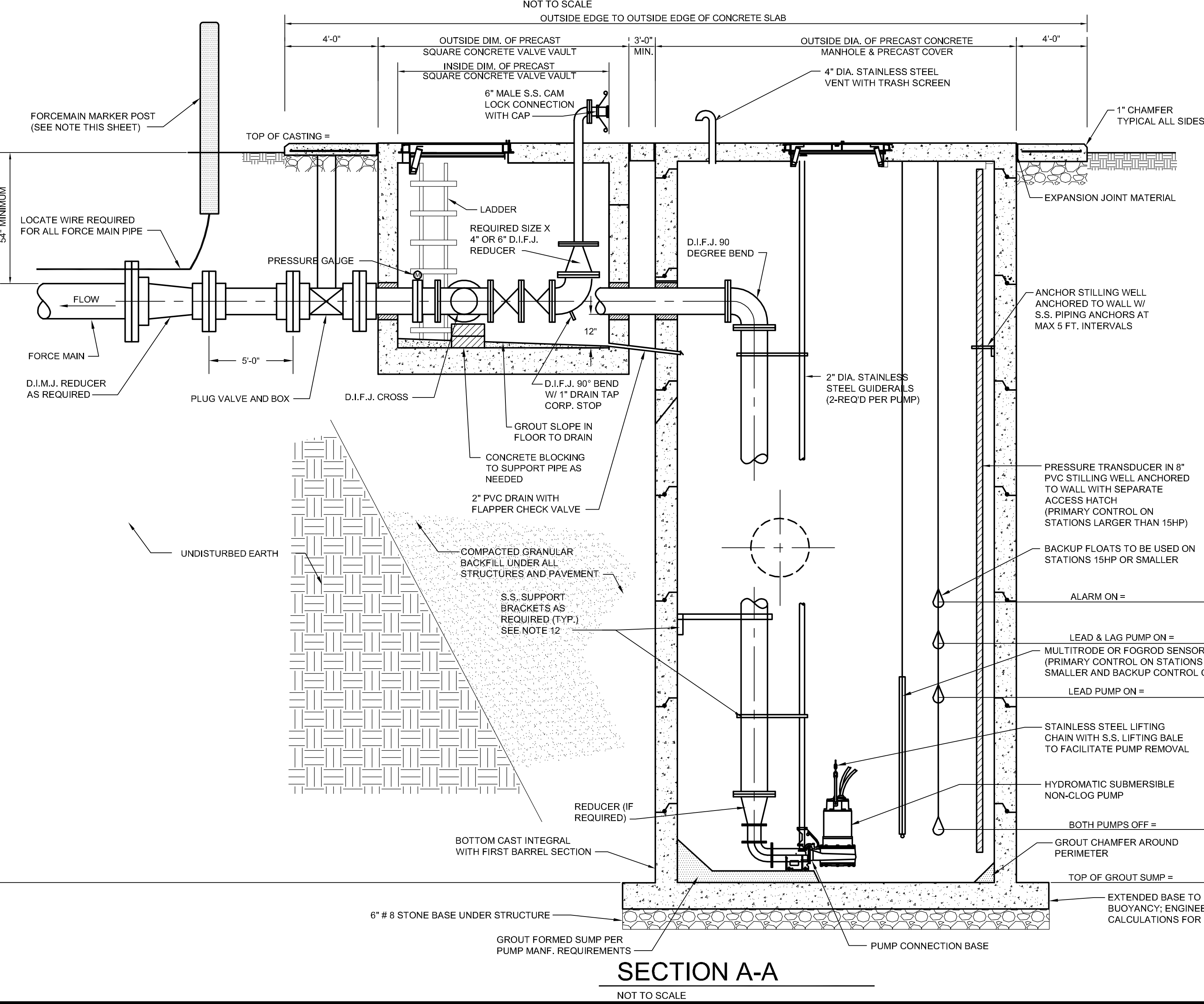
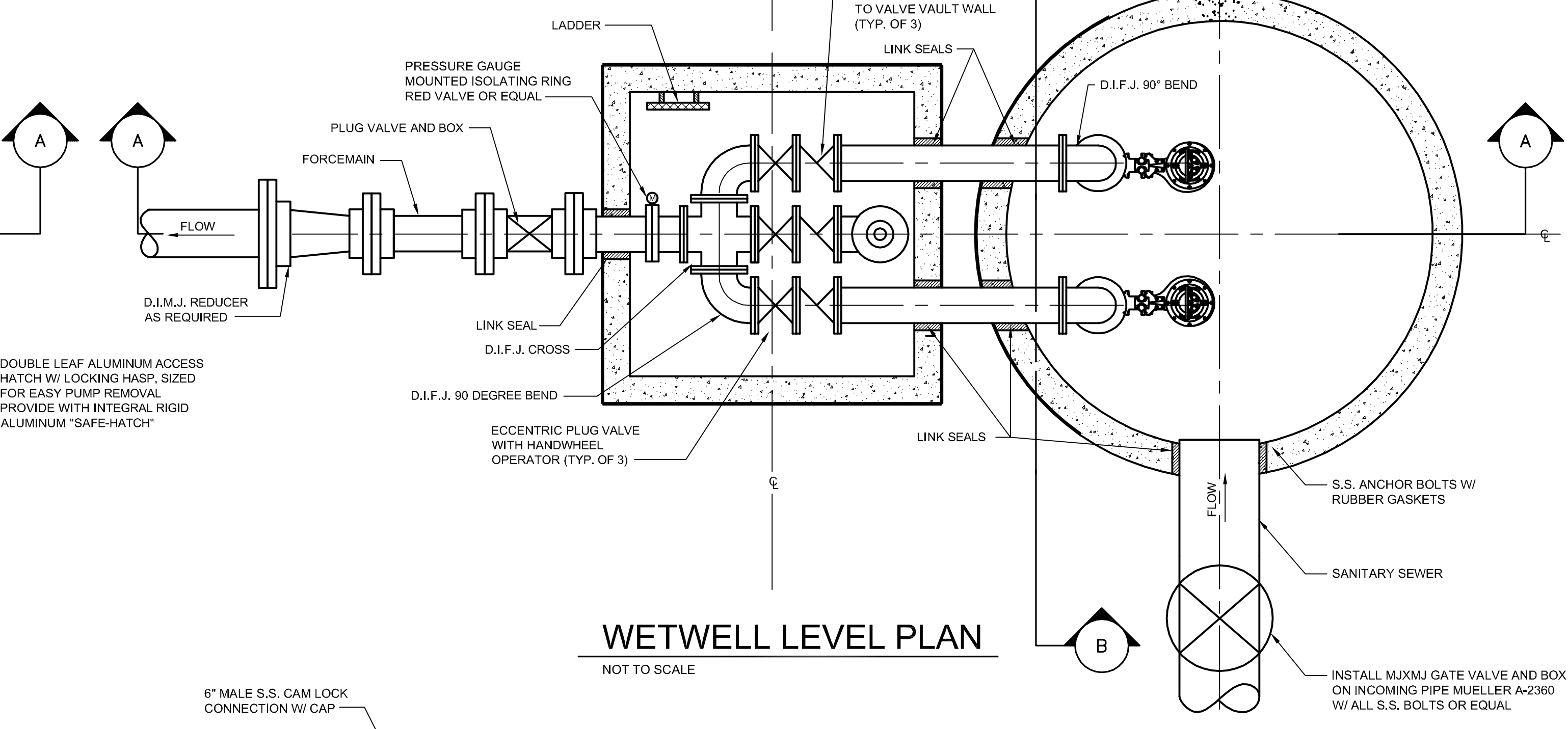
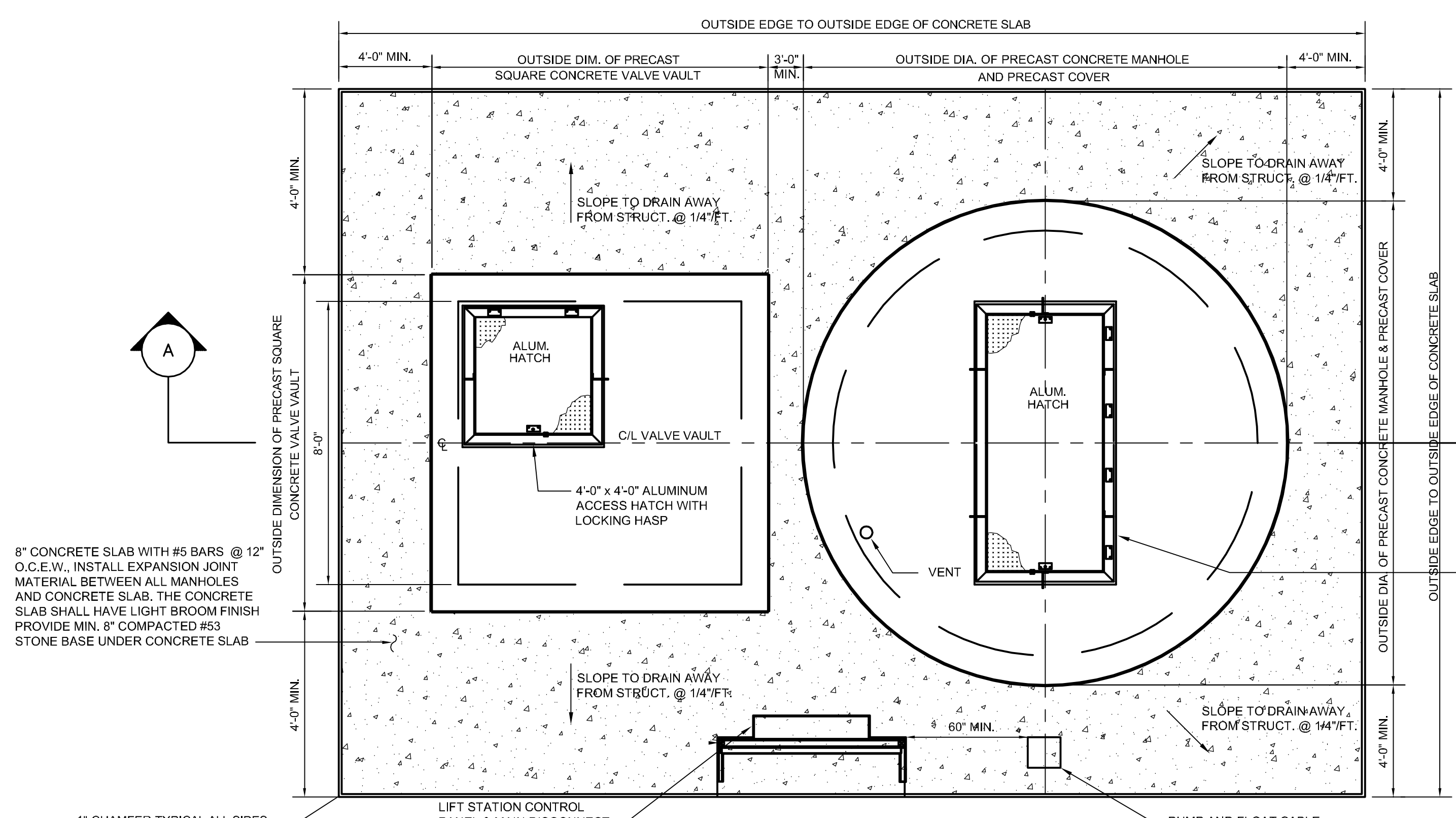

- LIFT STATION REQUIREMENTS:**
- WET WELL INTERIOR SURFACES, INCLUDING THE TOP, SHALL BE COATED ENTIRELY WITH THE FOLLOWING MATERIALS:
    - APPLY DIRECT TO PREPARED PRECAST CONCRETE SURFACE: EPOXY COATING MAINSTAY OR EQUAL PER MANUFACTURER'S RECOMMENDATIONS.
    - ALL PIPING SHALL BE PAINTED WITH:
      - 1ST COAT - TNE-MEC N14013 POTAPOX PLUS 4.0 - 6.0 MILS
      - 2ND COAT - TNE-MEC HIGH BUILD TNE-TAR 16.0 - 20.0 MILS OR EQUAL
  - THE VALVE VAULT PIPING AND VALVES AS WELL AS ABOVE GRADE PIPING SHALL BE PAINTED AS FOLLOWS:
    - 1ST COAT - TNE-MEC 91 H2O HYDRO ZINC 2.5 - 3.5 MILS
    - 2ND COAT - TNE-MEC N69 HIGH BUILD EPOXOLINE II 4.0 - 6.0 MILS
    - 3RD COAT - SAME AS 2ND 2.0-3.0 MILS
  - EXPANSION TESTING REQUIRED FOR LIFT STATION WET WELLS.
    - PLUG ALL INLET LINES BEFORE STARTING PRESOAK PERIOD.
    - PRESOAK PERIOD SHALL BE AT LEAST FOUR (4) HOURS.
    - FOLLOWING PRESOAK PERIOD, FILL STRUCTURE TO A DEPTH OF 6" BELOW THE TOP STRUCTURE JOINT.
    - TEST PERIOD SHALL BE TWO (2) HOURS. ANY DETECTABLE LEAKAGE SHALL BE CAUSE FOR REJECTION AND THE LEAKAGE SHALL BE CORRECTED AND RE-TESTING ACCOMPLISHED.
  - ALL BOLTS AND HARDWARE SHALL BE STAINLESS STEEL.
  - ENGINEER SHALL VERIFY THAT PUMPS CAN BE REMOVED FROM WETWELL VIA GUIDE RAILS THROUGH HATCH OPENING.
  - DEPENDENT ON THE SIZE AND SCOPE OF THE STATION, THE TOWN MAY REQUIRE THAT AN ELECTROMAGNETIC FLOW METER BE PROVIDED IN A SEPARATE VAULT WITH THE TRANSMITTER BOX INCORPORATED INTO THE STATION CONTROL PANEL.
  - ALL PIPING WITH 5 FT. AND INSIDE LIFT STATION SHALL BE DUCTILE IRON. INTERIOR JOINTS SHALL BE FLANGED; EXTERIOR JOINTS SHALL BE MJ.
  - CONTRACTOR MUST PROVIDE TOWN OF WHITESTOWN - WHITESTOWN MUNICIPAL UTILITIES WITH SHUT OFF WRENCH FOR ALL NECESSARY VALVES.
  - TRANSDUCER SHALL BE USED AS THE PRIMARY CONTROLLER.
  - VALVES SHALL BE DE ZURIK VALMATIC OR EQUAL.
  - ANCHOR PUMP DISCHARGE PIPE TO WALL AT MID POINT. IF LENGTH EXCEEDS 20 FT., PROVIDE 2 ANCHOR BRACKETS EVENLY SPACED. ANCHOR GUIDE RAILS PER MANUFACTURER'S RECOMMENDATIONS.

FILE NAME: L:\AutoCAD Resources\Info Sanitary\Client\Standards\Whitestown - 120409\Details 2015\SHEET\_11\_LS-DETAILS.dwg  
PRINTED: 7/30/2015 @ 3:21 PM  
DEPTH FROM TOP OF CASTING TO TOP OF GROUT SUMP